



CS72-HTC

SYSTEM MANUAL

Automated Motorized Hydraulic Traffic Controller

Spike Systems
3623 S. Seventh Street
Phoenix, Arizona 85040
Phone: (602) 243-0291
Fax: (602) 243-0294

Hydraulic Traffic Control Systems

This manual describes the operational requirements of the CS72-HTC Hydraulic Traffic Control System-SM/FM as it is normally configured on site.

TITLE PAGE		SECTION 3. INSTALLATION AND SETUP	
T-1	0	3-1	0
T-2	0	3-2	0
		3-3	0
LIST OF EFFECTIVE PAGES		3-4	0
LEP-1	0	3-5	0
LEP-2	0	3-6	0
		3-7	0
TABLE OF CONTENTS		3-8	0
TC-1	0	3-9	0
TC-2	0	3-10	0
		3-11	0
WARRANTY		3-12	0
WAR-1	0	3-13	0
WAR-2	0	3-14	0
		3-15	0
INTRODUCTION		3-16	0
INTRO-1	0		
INTRO-2	0		
		SECTION 4. HYDRAULIC CONTROL UNIT WIRING	
SECTION 1. DESCRIPTION		4-1	0
1-1	0	4-2	0
1-2	0	4-3	0
1-3	0	4-4	0
1-4	0	4-5	0
1-5	0	4-6	0
1-6	0		
1-7	0		
1-8	0		
		SECTION 5. MAINTENANCE	
SECTION 2. SAFETY PRECAUTIONS		5-1	0
2-1	0	5-2	0
2-2	0	5-3	0
		5-4	0
		APPENDIX A	
		A-1	0
		A-2	0

Blank Page

TABLE OF CONTENTS

Section 1.	Description	1-1
Section 2.	Safety Precautions	2-1
Section 3.	Installation and Setup	3-1
Section 4.	Hydraulic Control Unit Wiring	4-1
Section 5.	Maintenance	5-1

Blank Page

WARRANTY

SPIKE SYSTEMS, Inc., hereinafter referred to as **Spike systems**, warrants its products will be free from defects in workmanship and materials when installed, and used and serviced as intended, for a period of one (1) year from date of original invoice.

É CS72-HTC-SM Automated Hydraulic Traffic Control (Surface-Mount)

É CS72-HTC-FM Automated Hydraulic Traffic Control (Flush-Mount)

Spike Systems agrees to repair or replace, at **Spike Systems** choice and expense, any defective product at no additional charge. This warranty extends only to the original Purchaser. It is not transferable to anyone who subsequently purchases, leases, or otherwise obtains the Product from the original Purchaser. This warranty does not cover road surfaces, concrete or other structures, underground equipment or fittings, repair labor, travel time, mileage, shipping, or freight charges, taxes, preventive maintenance and inspections or the replacement of items that are by nature, consumable. No allowance for damages to equipment due to power fluctuations will be considered, a clean power supply is the responsibility of the customer. The warranty is voided if any modifications, changes or additions to the equipment are performed without written approval from **Spike Systems**. In addition, this warranty may be voided or further limited if required and or recommended repairs, maintenance, or inspections are not carried out as specified, or if defect is due to normal wear, misuse, abuse, accident, installation not in accordance with instructions or applicable codes, unauthorized repair or incidents commonly referred to as Acts of God. **Spike Systems** retains the right to the final determination as to the cause of any defect.

Except for the warranties set forth herein, **Spike Systems** disclaims all other warranties, expressed or implied or statutory, including but not limited to the implied warranties of merchantability, or fitness or suitability for any particular purpose, activity or location.

Spike Systems will in no event be liable for any loss of business, profits, data or use, or any direct, indirect, incidental or consequential damages resulting from any such defect in materials or workmanship. You agree that repair, replacement or refund, as applicable, under this warranty described herein is your sole and exclusive remedy with respect to any breach of the **Spike Systems** Limited warranty set forth herein.

Blank Page

INTRODUCTION

Spike Systems Hydraulic Traffic Control System (HTC) is designed to regulate the flow of traffic through a secure control point. The HTC is also designed and manufactured to ensure personnel safety when the equipment is operated properly and all safety precautions are strictly followed.

Persons responsible for the operation and field maintenance of the Model CS72-HTC system should read this manual carefully before attempting to operate the equipment or performing any service or adjustment procedures.

The Warnings, Cautions, and Notes in this manual represent the following information:

- A **WARNING** is an operation, procedure or condition that can cause injury or death.
- A **CAUTION** is an operation, procedure or condition that can cause damage to the equipment.
- A **NOTE** provides helpful information.

The warnings and cautions that follow apply to all parts of this manual.

- | |
|---|
| <p>WARNING: POTENTIALLY LIFE-THREATENING HAZARDS MAY EXIST DURING EQUIPMENT OPERATION. ONLY QUALIFIED PERSONNEL SHOULD ATTEMPT TO OPERATE, SERVICE OR MAKE ADJUSTMENTS TO THE HYDRAULIC TRAFFIC CONTROL SYSTEM EQUIPMENT.</p> |
| <p>WARNING: FOLLOW THE PRECAUTIONARY INSTRUCTIONS EXACTLY. DO NOT TAKE SHORTCUTS. DO NOT ASSUME THAT SOMEONE ELSE HAS ACTED ON YOUR BEHALF. IF ANY RULE OR PRECAUTION IS NOT CLEAR TO YOU, SEE YOUR SUPERVISOR BEFORE USING THE MACHINE.</p> |
| <p>WARNING: THIS UNIT CONTAINS A THERMALLY FUSED ELECTRIC MOTOR. IF THE MOTOR STOPS, DO NOT ASSUME POWER IS NOT PRESENT. UNEXPECTED MOTOR START-UP IS POSSIBLE AFTER PROTECTOR TRIPS. DISCONNECT POWER FROM CIRCUIT BEFORE PERFORMING ANY SERVICE TO THE MOTOR. WHEN POWER IS RECONNECTED, RESET PROTECTOR BEFORE ACTIVATING SYSTEM.</p> |
| <p>WARNING: TO AVOID PERSONAL INJURY, BE AWARE THAT VOLTAGES ARE PRESENT IN THE HYDRAULIC TRAFFIC CONTROL SYSTEM. VOLTAGES AS LOW AS 28 VOLTS CAN CAUSE SERIOUS INJURY UNDER SOME CONDITIONS. DO NOT BE MISLED BY THE TERM LOW VOLTAGE.</p> |

NOTE: Spike Systems assumes no liability for accident or injury incurred through improper use of this equipment.

WARNING: KEEP HANDS, FEET, AND CLOTHING CLEAR OF SPIKE PLATE WHILE OPERATING THE HYDRAULIC SYSTEM. INJURY OR DISMEMBERMENT COULD OTHERWISE OCCUR.

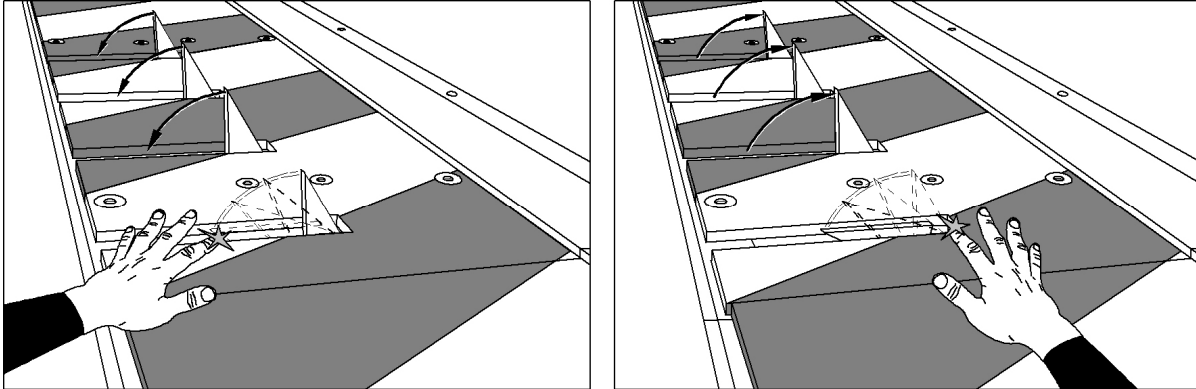

V01727

Abbreviation/Definition Table

Abbreviation	Definition
CW	Clockwise
CCW	Counter Clockwise
FM	Flush-Mount
HCU	Hydraulic Control Unit
HTC	Hydraulic Traffic Control
PLC	Programmable Logic Control
SM	Surface-Mount
STP	Slotted Top Plate
TCM	Traffic Control Module

SECTION 1. DESCRIPTION

Equipment Description

The CS72-HTC Hydraulic Traffic Control System is an automated, self-contained system capable of interfacing with various external devices and security systems. The CS72-HTC-SM and the CS72-HTC-FM regulates traffic flow through a secured control point with a visual and physical barrier. The system is designed for standard commercial traffic and operates as intended under the following assumptions:

- Vehicle weight is 22,000 pounds per axle or less
- Vehicles use low-pressure pneumatic tires
- Barrier crossing speed is **5 miles per hour or less**

The modular design of the system simplifies installation and maintenance. It also allows the barrier length to be extended in 3-foot increments up to a maximum of 30 feet. The CS72-HTC Hydraulic Traffic Control Systems are available in two configurations for above ground (surface-mount) or built-in (flush-mount) applications.

Surface-Mount Design (CS72-HTC-SM)

The CS72-HTC-SM (Figure 1-1) is bolted directly to an existing concrete surface with minimal surface preparation using 1/2"x 4 1/4" wedge anchor bolts.



V01749

Figure 1-1. CS72-HTC-SM (Surface-Mount)

Flush-Mount Design (CS72-HTC-FM)

The CS72-HTC-FM (Figure 1-2) is placed into the road surface and surrounded by a concrete structure.



V01794

Figure 1-2. CS72-HTC-FM (Flush-Mount)

The CS72-HTC Hydraulic Traffic Control System (Figure 1-3) consists of three main sections:

- Hydraulic Control Unit (HCU)
- Tunnel Section (TS)
- Traffic Control Module (CM)

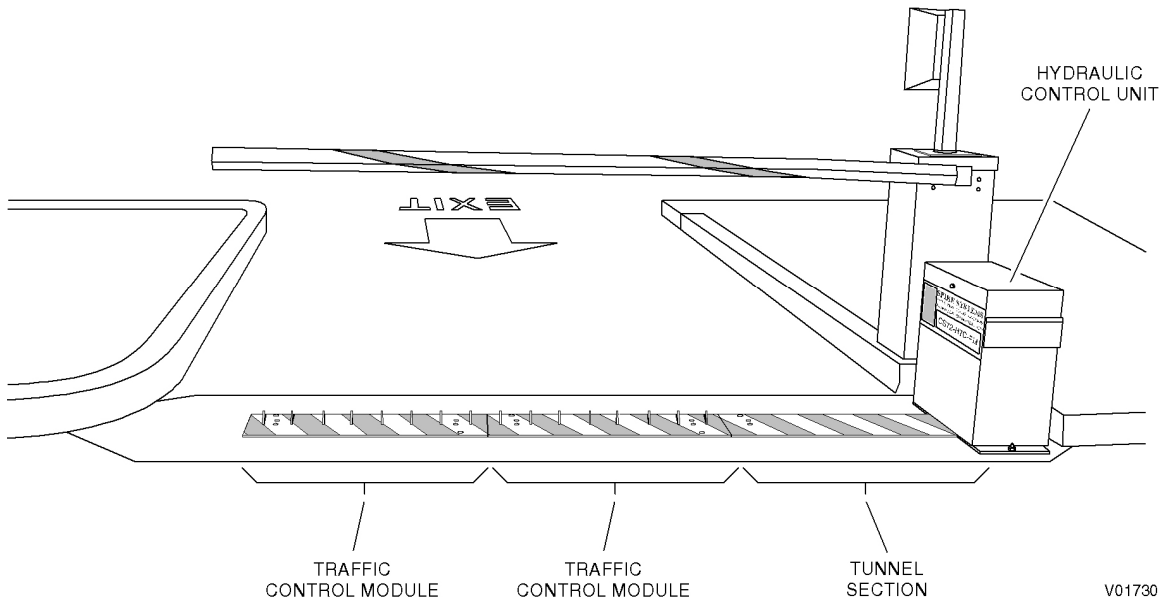

Figure 1-3. Hydraulic Traffic Control System

1. Hydraulic Control Unit

The Hydraulic Control Unit (HCU) contains the main components for internal system operation and is the primary controller of external devices (accessories) such as gates and traffic lights. Input signals from automatic sensors, keypads, manual switches, etc. are integrated and controlled by this unit. The major components of the hydraulic system (electric motor, pump and actuator) are housed within the Hydraulic Control Unit with an exception on a flush-mount system, where the hydraulic actuator is located in the Tunnel Section.

The Hydraulic Control Unit contains the following subassemblies:

- Hydraulic Pump Assembly (Figure 1-4)
- Control Panel (Figure 1-5)
- Manual Power On/Off Switch
- Up/Down Switch

WARNING: THIS UNIT CONTAINS A THERMALLY FUSED ELECTRIC MOTOR. IF THE MOTOR STOPS DO NOT ASSUME POWER IS NOT PRESENT. UNEXPECTED MOTOR START-UP IS POSSIBLE AFTER PROTECTOR TRIPS. DISCONNECT POWER FROM CIRCUIT BEFORE PERFORMING ANY SERVICE TO THE MOTOR. WHEN POWER IS RECONNECTED, RESET PROTECTOR BEFORE ACTIVATING SYSTEM.

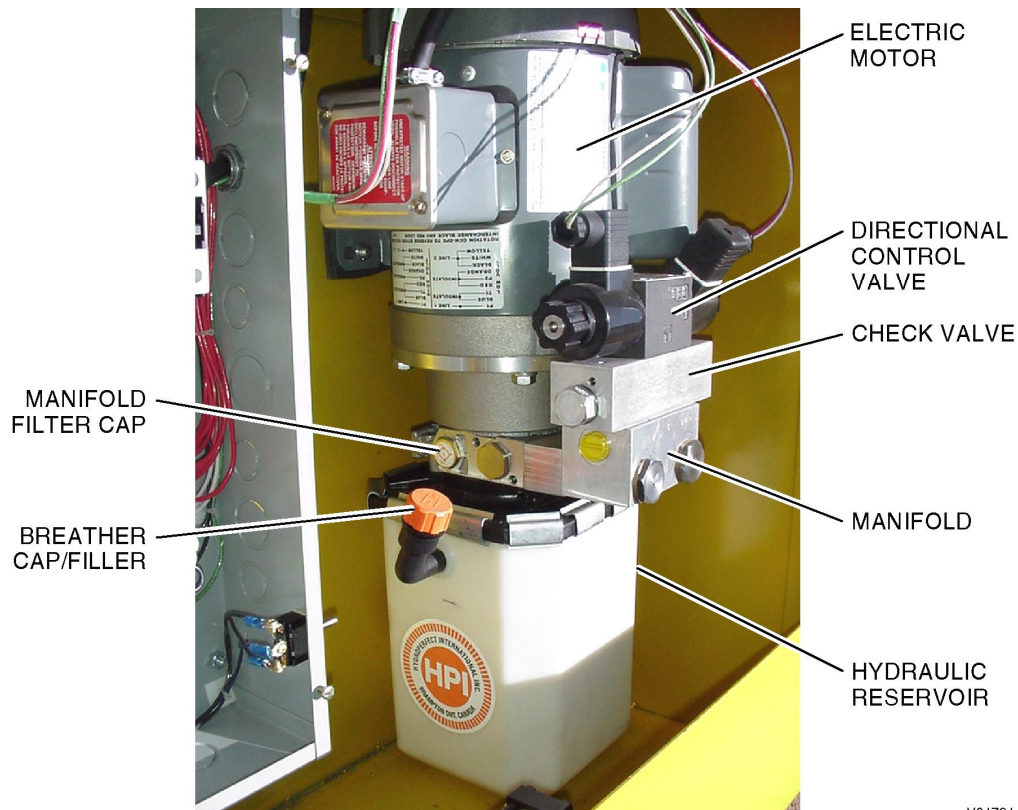

V01731

Figure 1-4. Hydraulic Pump

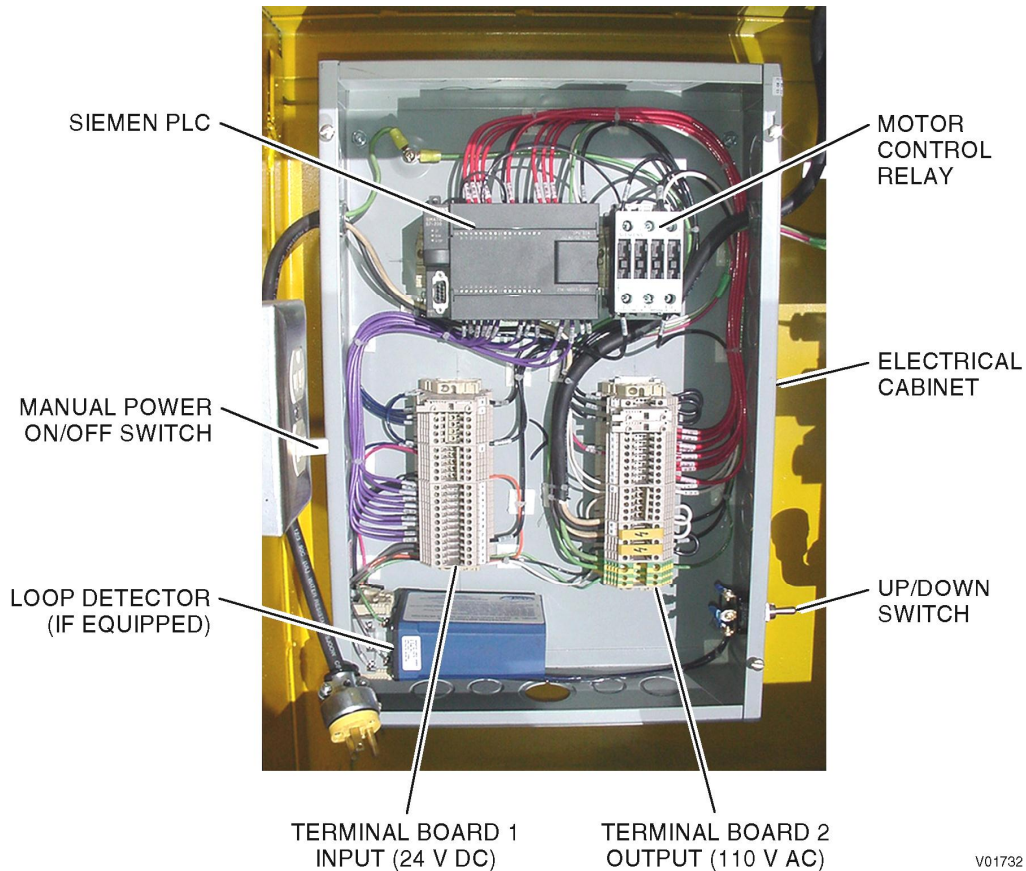

Figure 1-5. Control Panel

2. Tunnel Section

The Tunnel Section serves multiple purposes and although structurally different, it performs the same function on either a flush-mount or a surface-mount unit. As a structural component of the system, the Tunnel Section provides a mechanical interface between the Hydraulic Control Unit and Traffic Control Modules. A major difference between flush-mount and surface-mount systems is the location of the hydraulic actuator for the spike shaft. The hydraulic actuator is physically located in the Tunnel Section of flush-mount systems. The Tunnel Section allows the Hydraulic Control Unit to be positioned away from the path of vehicle traffic to avoid potential damage to the system. The 3-foot long Tunnel Section does not have spikes and provides a work area when the Hydraulic Control Unit is being accessed for maintenance or repair.

3. Traffic Control Module

Traffic Control Modules (Figure 1-6) share the same design configuration for both flush-mount and surface-mount units. The first Traffic Control Module in either system differs from other modules in the system because of the interface to the hydraulic actuator or spike shaft drive coupling. Traffic Control Modules are all 3-foot long sections that have eight spikes and consist of the following components:

- Slotted Top Plate
- Mount Block
- Spike Shaft
- Drive Coupling

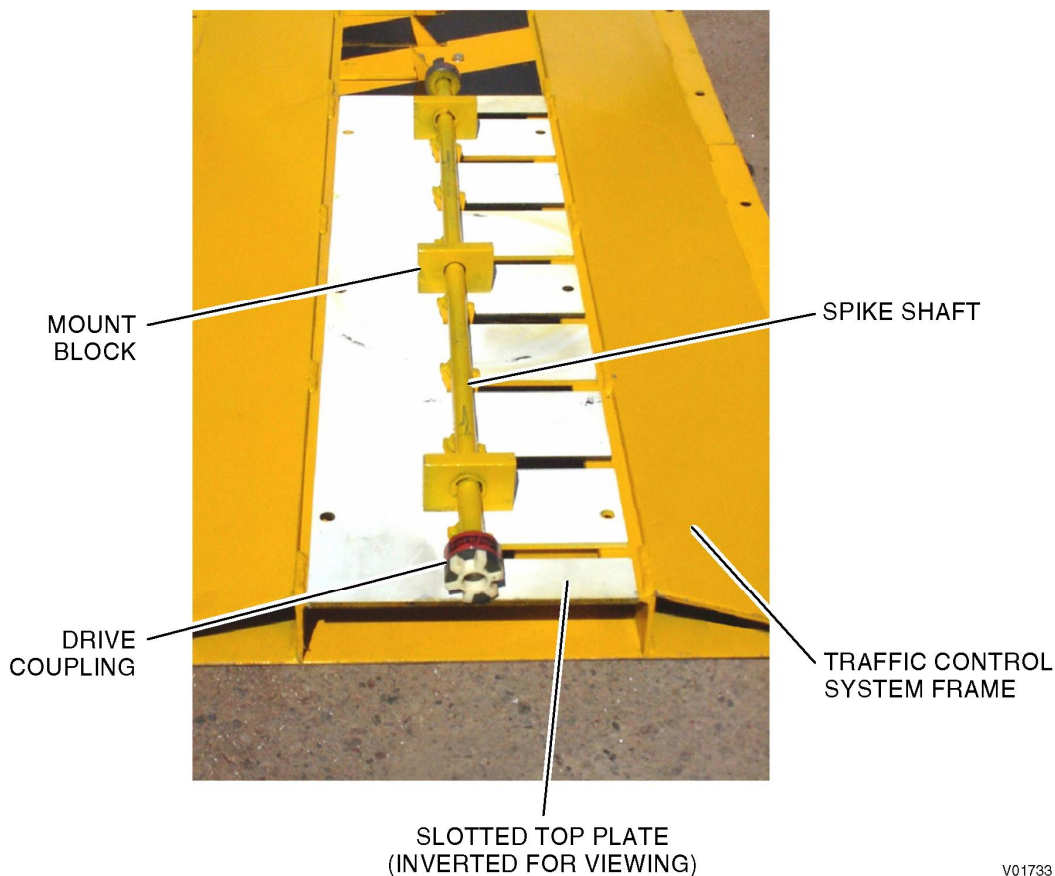

Figure 1-6. Traffic Control Module

Modules are removed and installed on the frame structure as an assembly. The components of a module are attached to the slotted top plate. The spike shaft and mount block components are manufactured together as a unit and can only be replaced as a single component.

Typical Operation

When using a Hydraulic Traffic Control System the recommended configuration of a traffic control point includes utilization of external devices. The external devices trigger an event sequence within the control system:

Event Sequence:

1. Vehicle approaches traffic control point
2. Control panel is accessed or personal access card is used, etc.
3. Spikes retract, send open signal to gate
 - A. Gate arm lifts/opens (if equipped)
 - B. Signal light changes from red to yellow (if equipped)
4. Vehicle moves beyond traffic control point
 - A. Gate arm lowers/closes (if equipped)
 - B. Signal light changes from yellow to red (if equipped)
5. Spikes extend with a signal from the HCU (signal input from personnel at exit access point or from Loop Detector Sensor, if so equipped).

Operational Description

The basic function of the Hydraulic Traffic Control System is to extend and retract a row of spikes to control the entry and/or exit of vehicles at a secure control point. As part of a spike shaft assembly, the spikes start above the road surface (close position), and are rotated 90 degrees to retract below the road surface (open position).

The electrical motor drives the hydraulic pump which sends hydraulic fluid through a directional control valve, check valve and manifold to a hydraulic actuator. The actuator is coupled to the spike shaft and transfers hydraulic power to rotate the spikes to the open or close position.

Two limit switches (open and close) are mounted to the hydraulic actuator and shut off power to the Directional Control Valve (Figure 1-4) when full retraction or extension of the spike shaft is reached.

The HCU programmable logic controller (PLC) has a built-in, 5-second shutdown delay, which prevents damage to the hydraulic pump. This feature is activated when the limit switch fails to send a shutdown signal. The limit switches are adjusted for full extend and retract during installation of the system.

Operational Sequence

When the hydraulic control unit receives an open input signal (via keypad entry, access card, manual switch, etc.) the PLC sends a signal to retract the spikes into the Traffic Control Module (open). The electric motor starts and runs for 0.10 seconds before the open (green) solenoid is energized. The 0.10-second delay allows the hydraulic pump to reach operational pressure before the directional control valve is opened. The open solenoid is energized for 5 seconds or until it receives a signal from the open limit switch to indicate the spikes are retracted.

With the open solenoid on the Directional Control Valve energized, hydraulic fluid is sent to the hydraulic actuator and the spike shaft rotates to the open position. Once the actuator rotates to the full open position, the limit switch shuts off power to the Directional Control Valve. When the PLC receives the open limit switch OPEN indication, it performs several control functions. The open solenoid on the Directional Control Valve is deenergized and the hydraulic pump continues to run in the bypass mode with the spikes retracted. The PLC sends additional control outputs to any external components of the system such as a gate or signal light.

Once the vehicle exits the control point, an optional loop sensor or other closing device sends a signal to the PLC to initiate the close sequence. The PLC sends control outputs to the external components of the system (gate, signal light, etc.). The close (red) solenoid on the Directional Control Valve is energized. Hydraulic fluid is sent to the hydraulic actuator and the spike shaft rotates to the extended or close position. The close solenoid is energized for 5 seconds or until it receives a signal from the close limit switch to indicate the spikes are extended. When the actuator rotates to the closed position the limit switch provides the extended or CLOSED indication to the PLC. The close solenoid on the Directional Control Valve is de-energized and the hydraulic pump continues to run in the bypass mode with the spikes extended. The pump will continue to run for 2 minutes and stop if no other control inputs are received.

SECTION 2. SAFETY PRECAUTIONS

Personal Safety

WARNING: STAY CLEAR OF THE SPIKE RETRACTION AREA. THE SPIKES ARE HYDRAULICALLY ACTIVATED AND CAN CAUSE PINCHING OR DISMEMBERMENT.

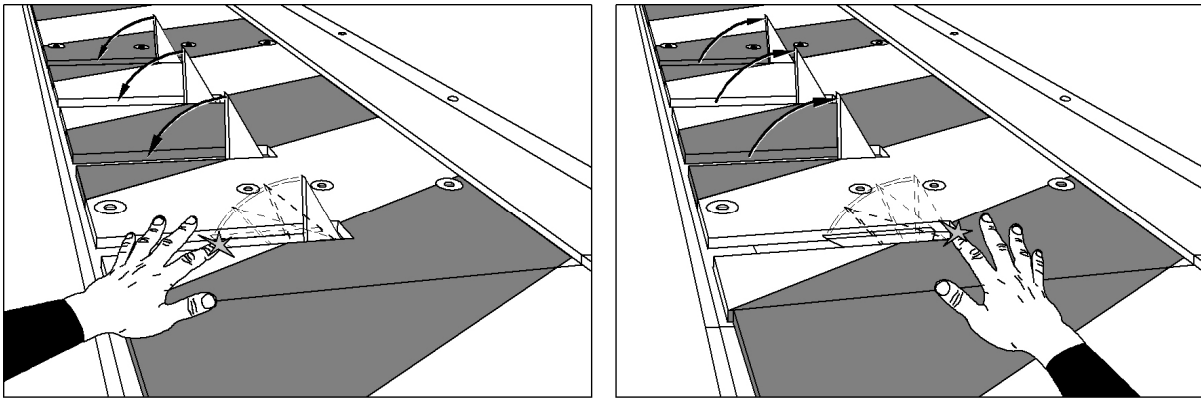

V01727

Safety Rules

Read each safety rule and make them a part of your daily work routine.

WARNING: FOLLOW THESE PRECAUTIONARY INSTRUCTIONS EXACTLY. DO NOT TAKE SHORTCUTS. DO NOT ASSUME THAT SOMEONE ELSE HAS ACTED ON YOUR BEHALF. IF ANY RULE OR PRECAUTION IS NOT CLEAR TO YOU, SEE YOUR SUPERVISOR BEFORE USING THE MACHINE.

WARNING: TO AVOID PERSONAL INJURY, BE AWARE THAT VOLTAGES ARE PRESENT IN THE HYDRAULIC TRAFFIC CONTROL SYSTEM. VOLTAGES AS LOW AS 28 VOLTS CAN CAUSE SERIOUS INJURY UNDER SOME CONDITIONS. DO NOT BE MISLED BY THE TERM LOW VOLTAGE.

WARNING: THIS UNIT CONTAINS A THERMALLY FUSED ELECTRIC MOTOR. IF THE MOTOR STOPS DO NOT ASSUME POWER IS NOT PRESENT. UNEXPECTED MOTOR START-UP IS POSSIBLE AFTER PROTECTOR TRIPS. DISCONNECT POWER FROM CIRCUIT BEFORE PERFORMING ANY SERVICE TO THE MOTOR. WHEN POWER IS RECONNECTED, RESET PROTECTOR BEFORE ACTIVATING SYSTEM.

Warning Signs

It is important to provide the following signs at all traffic control locations:



V01799

SECTION 3. INSTALLATION AND SETUP

Figure 3-1 and Figure 3-2 show recommended control locations and safe distances for a typical CS72-HTC Hydraulic Traffic Control (HTC) System.

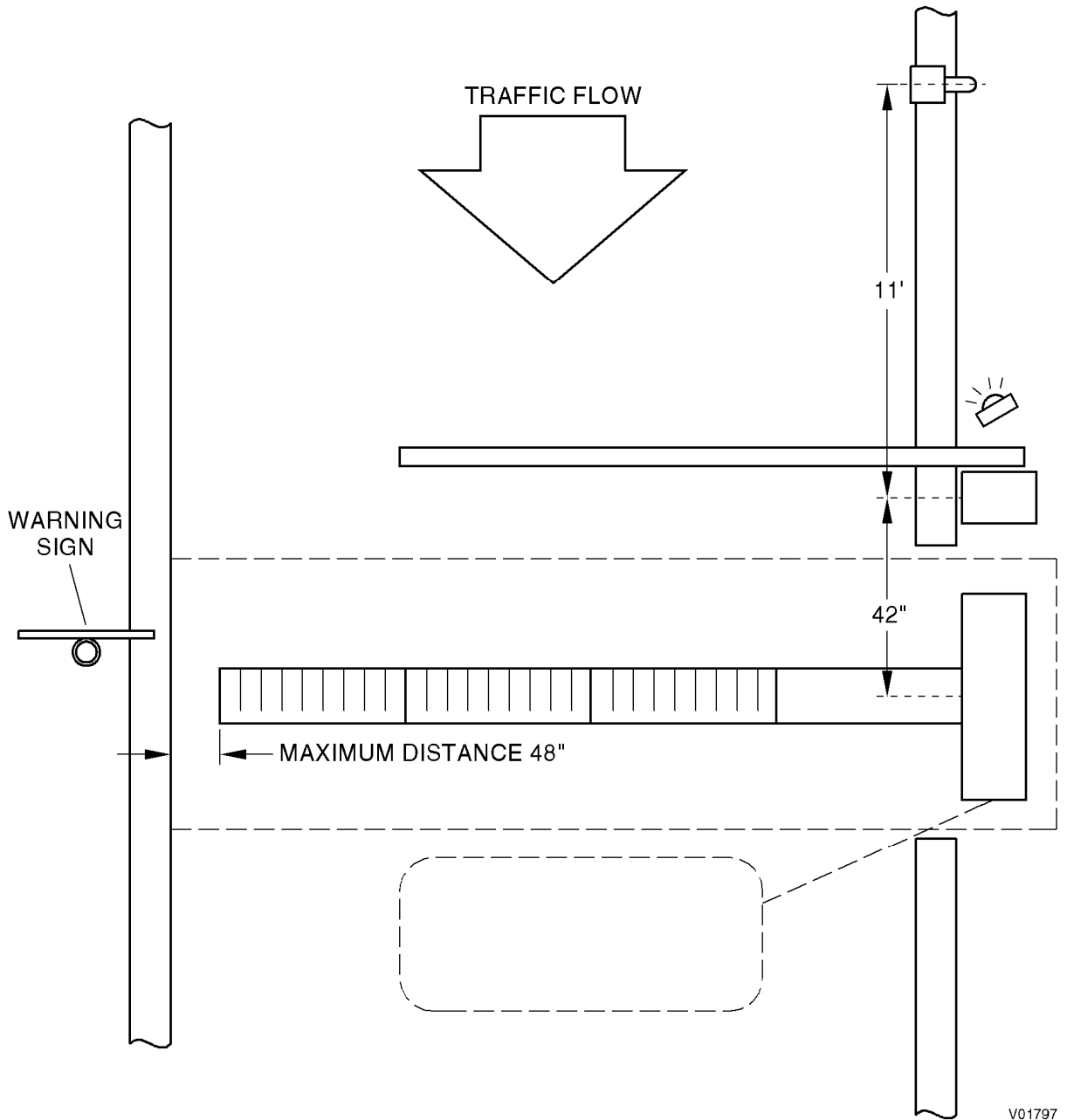

Figure 3-1. Typical CS72-HTC System Layout

Figure 3-2. System Layout (continued)

Site Selection

Locate and accurately direct your pedestrian and vehicle traffic to ensure trouble-free operation of your Hydraulic Traffic Control System. Site selection is your first priority, and the following steps must be met to validate any warranty, implied or real.

NOTE: If you have any questions concerning the traffic control site you are considering, call Gort for recommendations. Certain situations will invalidate your warranty:

1. Locate the HTC away from pedestrian traffic and restrict pedestrian traffic.
2. The HTC must be located in a flat section of driveway with adequate drainage so water does not build up in the unit and potentially cause slow operation of the spikes.
3. Locate the HTC at a 90 degree angle to the traffic flow. If necessary place barriers so wide turns cannot be made across the spikes. Crossing the spikes at any angle other than 90 degrees can cause tire sidewall damage.
4. Locate the unit where the maximum speed across the HTC is 5 mph. Higher speeds cause excessive wear on the spikes and top plates. If necessary, speed bumps and/or signs should be installed to control the speed.
5. Locate the HTC back far enough from the street so an exiting car can clear the spikes and any control devices completely while waiting to pull out into traffic. If there is not enough clearance, vehicles may inadvertently backup over the equipment.
6. Make sure the unit is not located where a driver could back out of a parking space and inadvertently cross the unit.
7. Provide adequate nighttime illumination of the unit and signs warning of its presence and potential tire damage.

Flush-Mount System Installation

NOTE: The following procedure and figures are for a typical system installation where the Hydraulic Control Unit is positioned on the left (driver side) and the Traffic Control Modules extend to the right. Installation of a system with the Hydraulic Control Unit positioned on the right (passenger side) is identical however, assembly and set-up is different. Refer to **Configuring the Control Unit for Right or Left Operation.**

1. Locate the Hydraulic Traffic Control System.
2. Mark the Slotted Top Plate of the Traffic Control Module (TCM) that connects to the Tunnel Section. This Slotted Top Plate must be reinstalled in its original position.
3. Remove the six outer bolts from the Slotted Top Plate on each TCM and remove the TCMs from the flush-mount frame assembly.
4. Remove the Top Plate from the Tunnel Section. Place a plastic bag or protective covering over the Hydraulic Actuator located in the Tunnel Section.
5. If necessary, attach any additional flush-mount frame sections to the main assembly with four bolts and four nuts.
6. Excavate a trench approximately 48 inches wide by 13 inches deep. The trench length is dependent on the length of the flush-mount frame utilized in the system. Allow an additional 6 inches at each end of the flush-mount frame (Figure 3-3) for clearance.

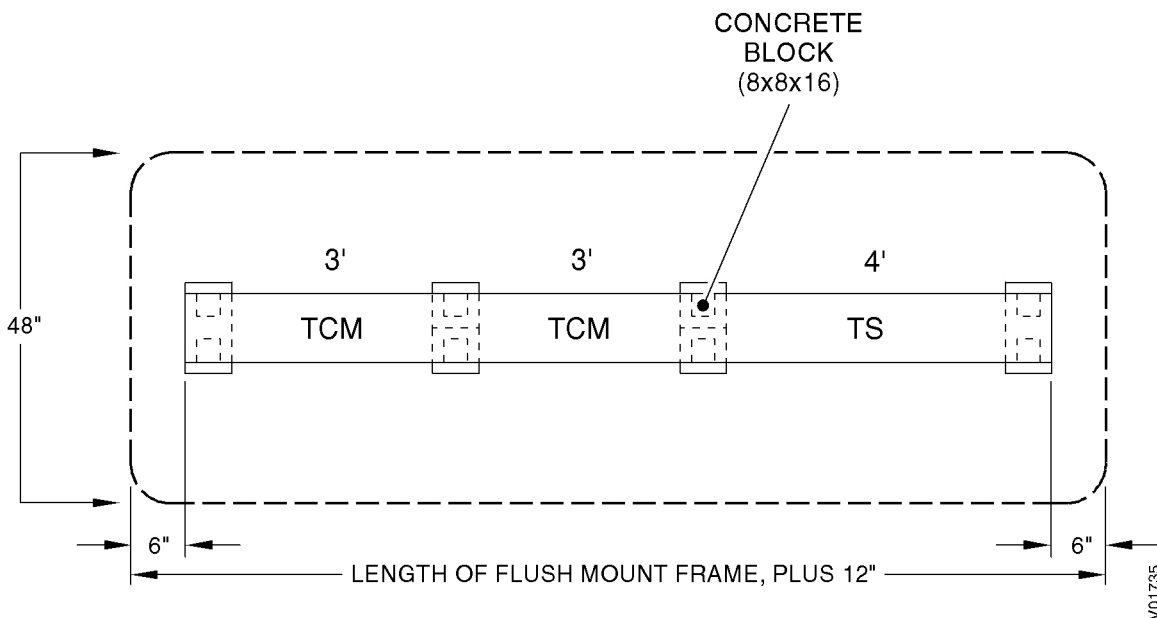

Figure 3-3. Installation CS72-HTC-FM Top View

7. Place a concrete block (8-x 8-x 16+) into the trench and position one at the end of each TCM and one at the end of the Tunnel Section (Figure 3-3 and Figure 3-4).

NOTE: All concrete blocks must be level with each other. This provides an even work surface on which to place the flush-mount frame.

- Fill the center of each concrete block with pea gravel. This provides drainage when water enters the system.

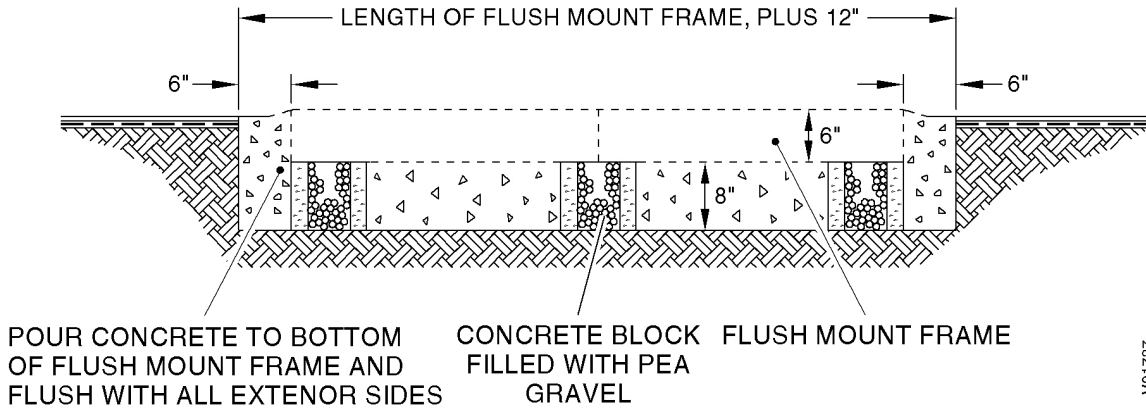

Figure 3-4. Installation CS72-HTC-FM Horizontal View

NOTE: The top of the flush-mount frame should be approximately 1/2" to 3/4" above the pavement. This provides for a run-off of water away from the Hydraulic Traffic Control System (Figure 3-5).

- Place the flush-mount frame assembly into the trench. Level the frame assembly on the concrete blocks and center it within the trench.

CAUTION: DO NOT ALLOW CONCRETE TO GET INSIDE OF THE FLUSH-MOUNT FRAME OR ON TO THE HYDRAULIC ACTUATOR.

TOP OF THE FLUSH MOUNT FRAME SHOULD BE APPROXIMATELY 1/2" TO 3/4" ABOVE FINISH PAVEMENT (THIS WILL HELP PREVENT WATER FROM DRAINING DIRECTLY INTO CONTAINER BOX)

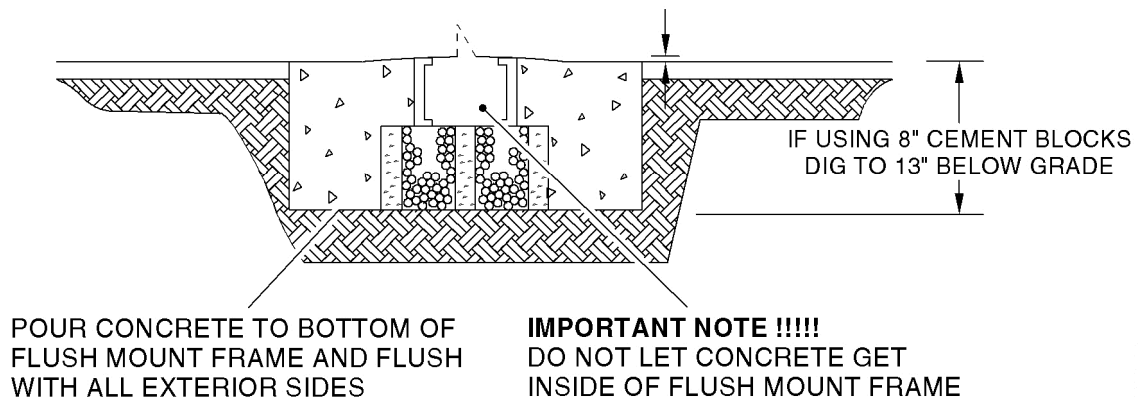
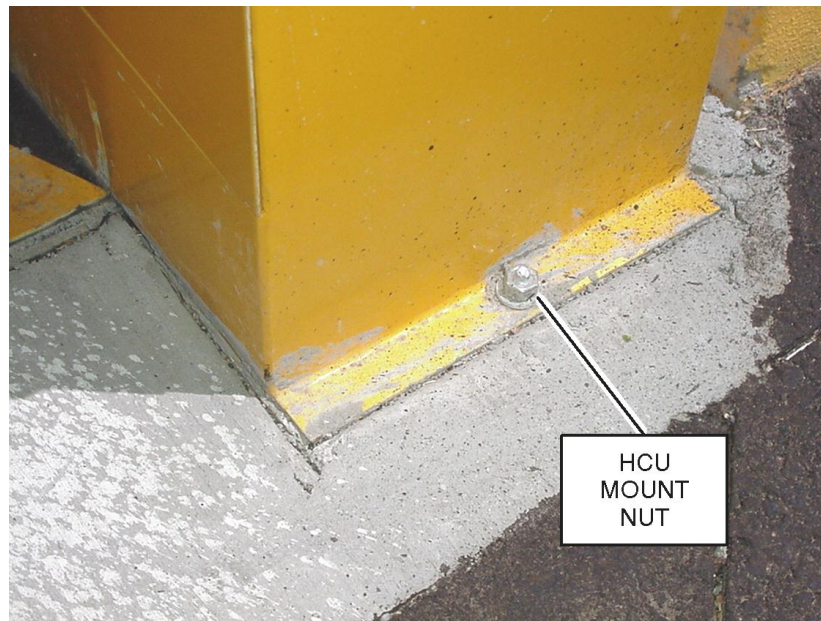

Figure 3-5. Installation CS72-HTC-FM End View

10. Pour concrete to fill the trench to the top of the flush-mount frame. Do not let concrete enter the bottom of the flush-mount frame. Protect the hydraulic actuator during fill.
11. Allow the concrete to set. Clean any excess concrete from inside the flush-mount frame assembly and remove the protective covering from the hydraulic actuator.
12. Temporarily install the Tunnel Section top plate.
13. Position the Hydraulic Control Unit at the end of the Tunnel Section. Allow a 1/8+ gap between tunnel section top plate and the control unit box.
14. Mark the location of the Hydraulic Control Unit mount holes on the concrete (Figure 3-6), remove the unit and install the 1/2+x 2 3/4+wedge anchor bolts. Refer to Appendix A for anchor bolt specifications and installation.



V01739

Figure 3-6. HCU Mount Nut Location

15. Position the Hydraulic Control Unit over the anchor bolts and secure the unit to the concrete.
16. Remove the Tunnel Section top plate.

17. Rotate the Hydraulic Actuator drive coupling to the spikes extended (up) position. This is different for left-hand or right-hand configuration systems (Figure 3-7).

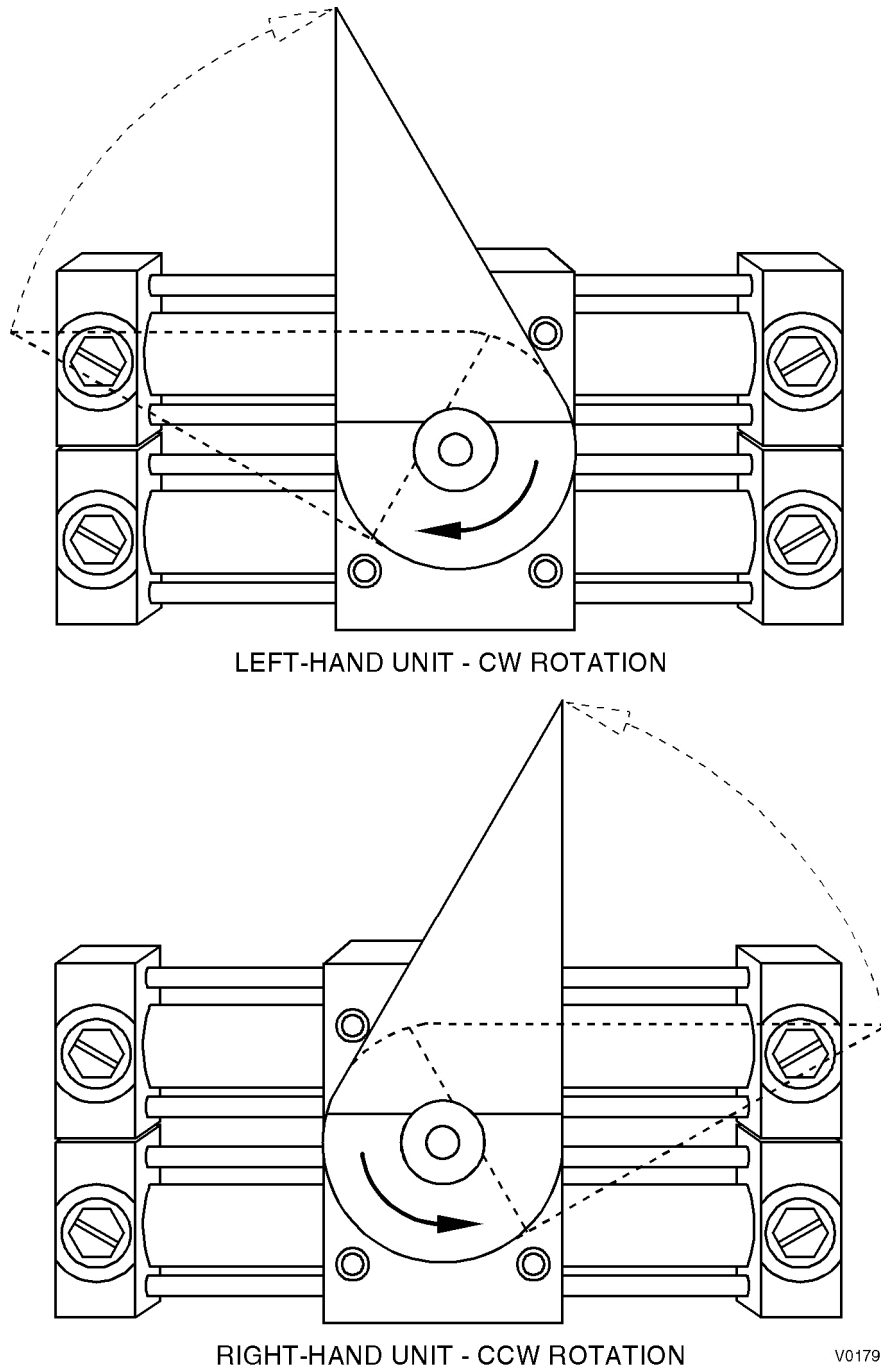

Figure 3-7. Hydraulic Actuator Position

18. Locate the Slotted Top Plate that was marked in step 2. Rotate and hold the spike shaft assembly in the extended (up) position.

19. With the spikes in the extended position, align the spike shaft drive coupling with the hydraulic actuator drive coupling and slide the TCM against the tunnel section as it is positioned on the flush-mount frame.
20. Install the six outer bolts that secure the TCM to the flush-mount frame assembly. Do not tighten.
21. Replace each additional TCM on the flush-mount frame with the spikes extended and install the six outer bolts for each Slotted Top Plate. Do not tighten.
22. Attach the hydraulic lines to the hydraulic actuator in the Tunnel Section. Red connector to Red line and Green connector to Green line.
23. Run the hydraulic lines through the Tunnel Section and into the Hydraulic Control Unit.
24. Tighten the outer bolts on the TCMs.
25. Connect the actuator limit switch wiring to the HCU, (see CONFIGURING FOR LEFT OR RIGHT HYDRAULIC CONTROL UNIT INSTALLATION in this section).
26. Adjust the spike shaft travel, (see Section 5, Maintenance).
27. Install the Tunnel Section top plate. Check for alignment or interference with the Hydraulic Control Unit box and secure with six bolts.

Surface-Mount System Installation

NOTE: Installation of the CS72-HTC-SM System, Left or Right is identical. Only the Left mount will be covered.

NOTE: The mount hole positions for the CS72-HTC-SM-L/R must be established before the system is installed on the road surface.

1. Locate the CS72-HTC-SM on a flat surface.
2. Slide the Tunnel Section to connect with the Hydraulic Control Unit and align the drive coupling with the Hydraulic Actuator.
3. Install two bolts and two nuts to secure the Tunnel Section to the Hydraulic Control Unit.
4. Slide the TCM to connect with the Tunnel Section and align the drive couplings.
5. Install two bolts and two nuts to secure the TCM to the Tunnel Section.
6. Slide the remaining TCMs together aligning the drive couplings.
7. Install the two bolts and two nuts to secure the TCMs together.

NOTE: All installation hardware must meet **Rowers+Fasteners Wedge Anchor** or **RED HEAD**+concrete anchoring systems specifications (see Appendix A)

8. Install six anchor bolts to secure each TCM and the Tunnel Section to the road surface.
9. Install the retaining nuts for the Hydraulic Control Unit.

CONFIGURING FOR LEFT OR RIGHT HYDRAULIC CONTROL UNIT INSTALLATION

The CS72-HTC can be configured for Hydraulic Control Unit (HCU) installation on the right or left side of the Hydraulic Traffic Control System. Figure 3-8 shows the left-hand configuration of a surface-mount unit. The configuration of the HCU is slightly different for right and left installation. The hydraulic port connector positions and extend and retract travel limit sensor wiring are different for left and right HCU installations.

The proper configuration of hydraulic port connectors and travel limit sensors for the left-hand HCU installation is shown in Figure 3-9 and Figure 3-11. The proper configuration of hydraulic port connectors and travel limit sensors for the right-hand HCU installation is shown in Figure 3-10 and Figure 3-12.



V01811

Figure 3-8. Left-Hand Hydraulic Control Unit Configuration

Hydraulic Port Configuration (if required)

1. Remove electrical power to the Hydraulic Control Unit.
2. Loosen the center screw securing each port connector to the directional control valve solenoids.
3. Carefully disconnect the port connector from the directional control valve solenoid and reconnect to the opposite solenoid. See Figure 3-9 or Figure 3-10 for proper wiring configuration.

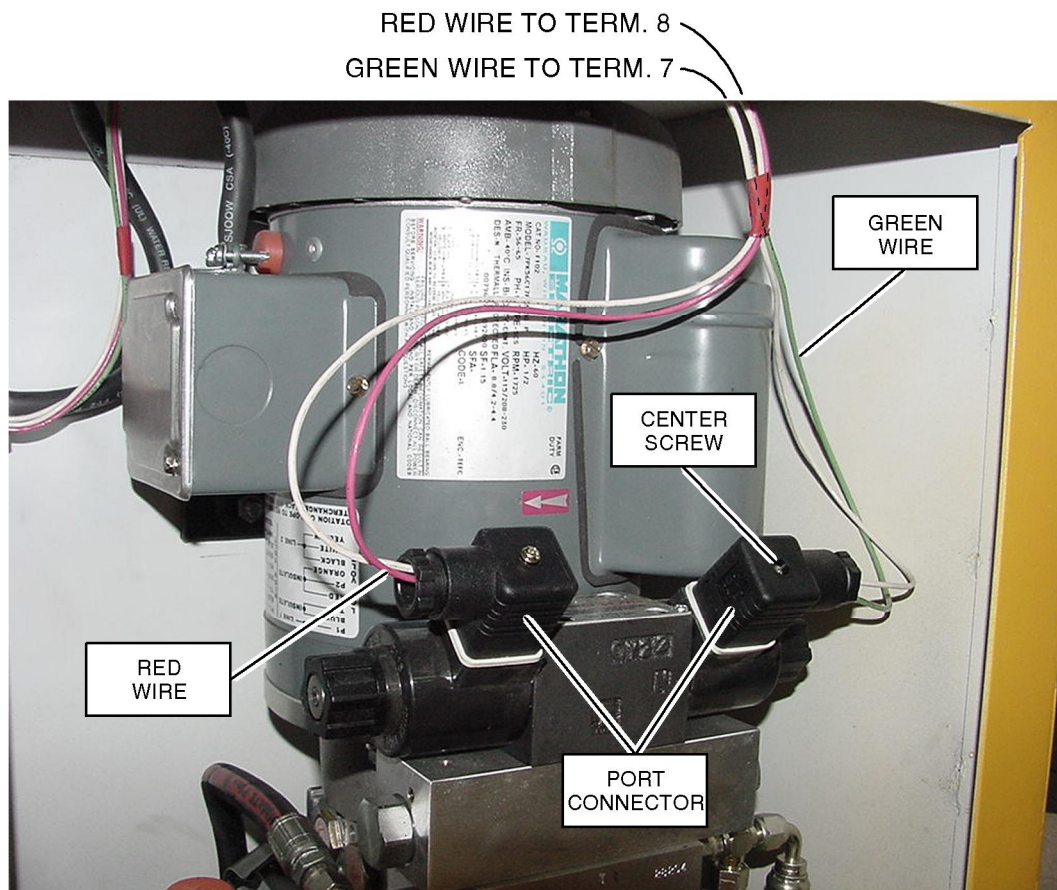

V01741

Figure 3-9. Left-Hand Port Connector Configuration

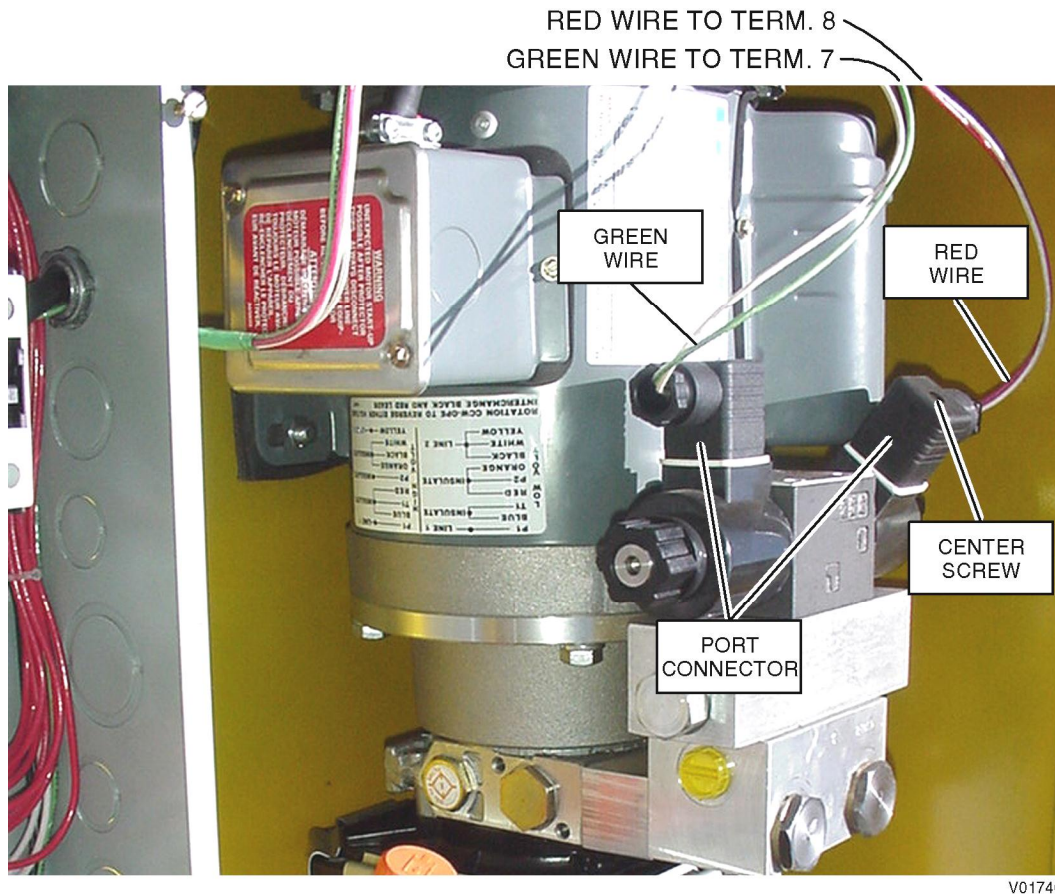

Figure 3-10. Right-Hand Port Connector Configuration

Extend and Retract Limit Switch Configuration (if required)

1. Remove electrical power to the Hydraulic Control Unit.

WARNING: DO NOT REMOVE OR INSTALL LIMIT SWITCHES WITH HYDRAULIC POWER APPLIED. SERIOUS PERSONAL INJURY CAN RESULT WHEN ROTARY ACTUATOR IS ACTIVATED.

2. Loosen 2 setscrews at the top of each limit switch just enough to allow the limit switch to be removed from the shaft (Figure 3-11).
3. Remove wire ties and clamps as necessary.
4. Reposition limit switches for left or right configuration as shown in Figure 3-11 and Figure 3-12. Position limit switches on shaft approximately as shown.
5. Tighten setscrews to hold limit switches in place.
6. Install wire ties and clamps.
7. Perform spike shaft travel adjustment procedure in Section 5, Maintenance.

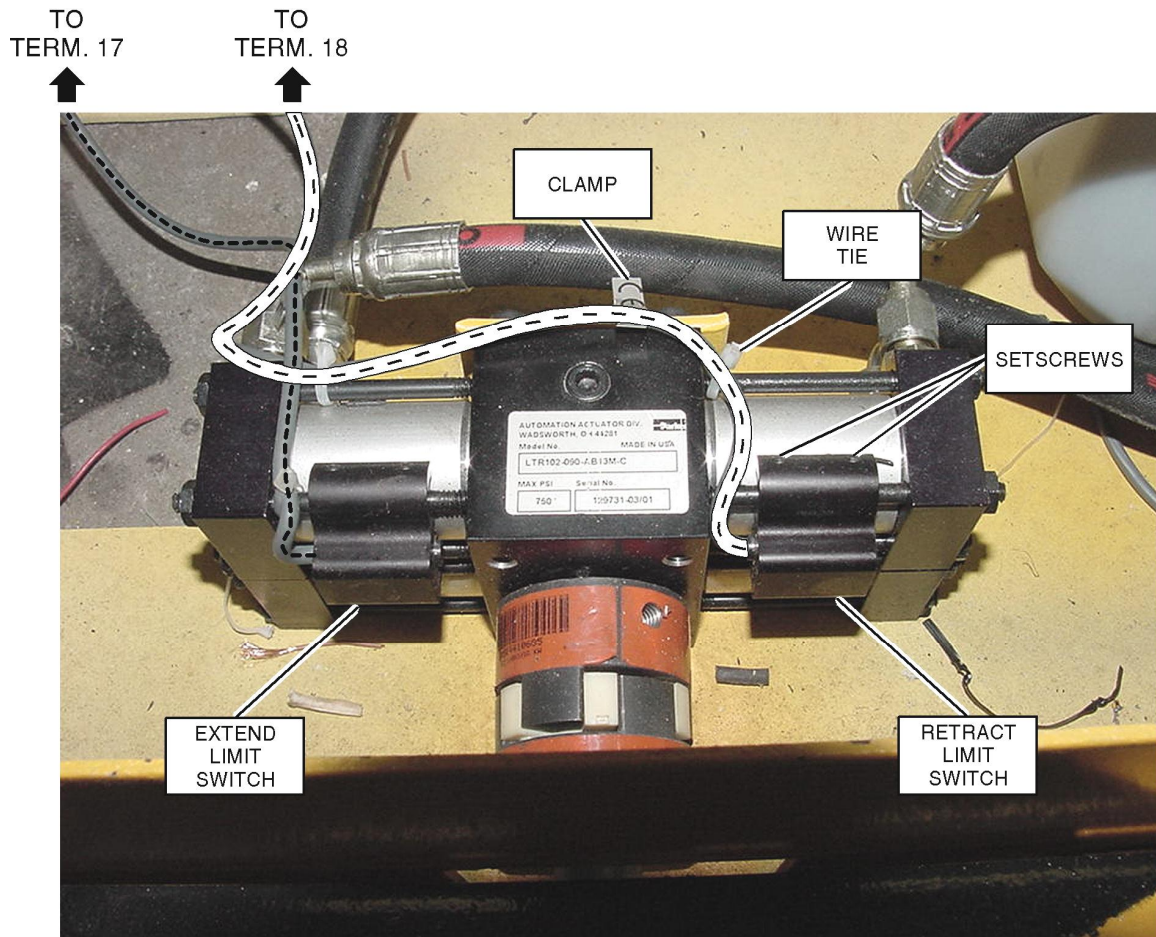

V01743

Figure 3-11. Left-Hand Limit Switch Configuration

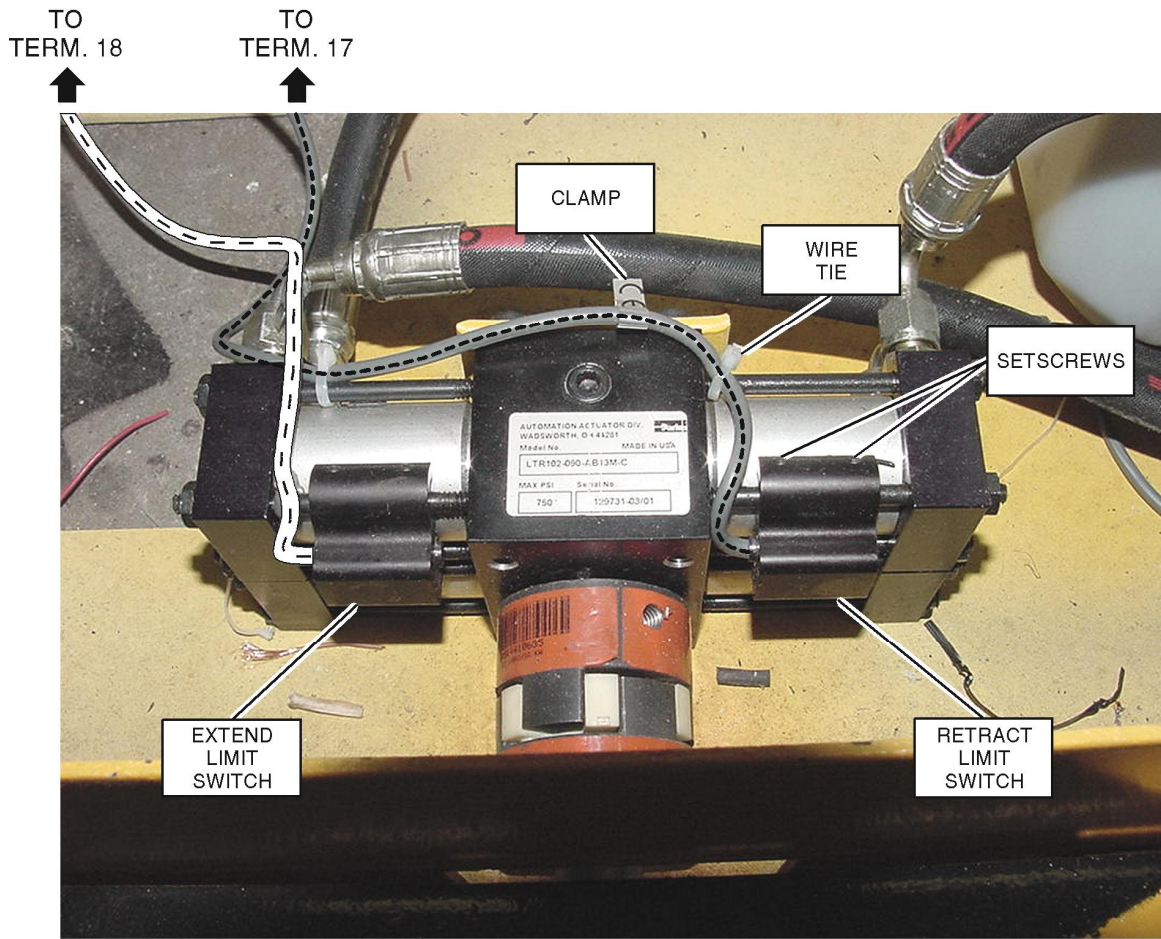

Figure 3-12. Right-Hand Limit Switch Configuration

CS72-HTC WIRING DIAGRAMS

Basic electrical wiring information for the CS72-HTC Hydraulic Traffic Control System is shown in Figure 3-13 and Figure 3-14.

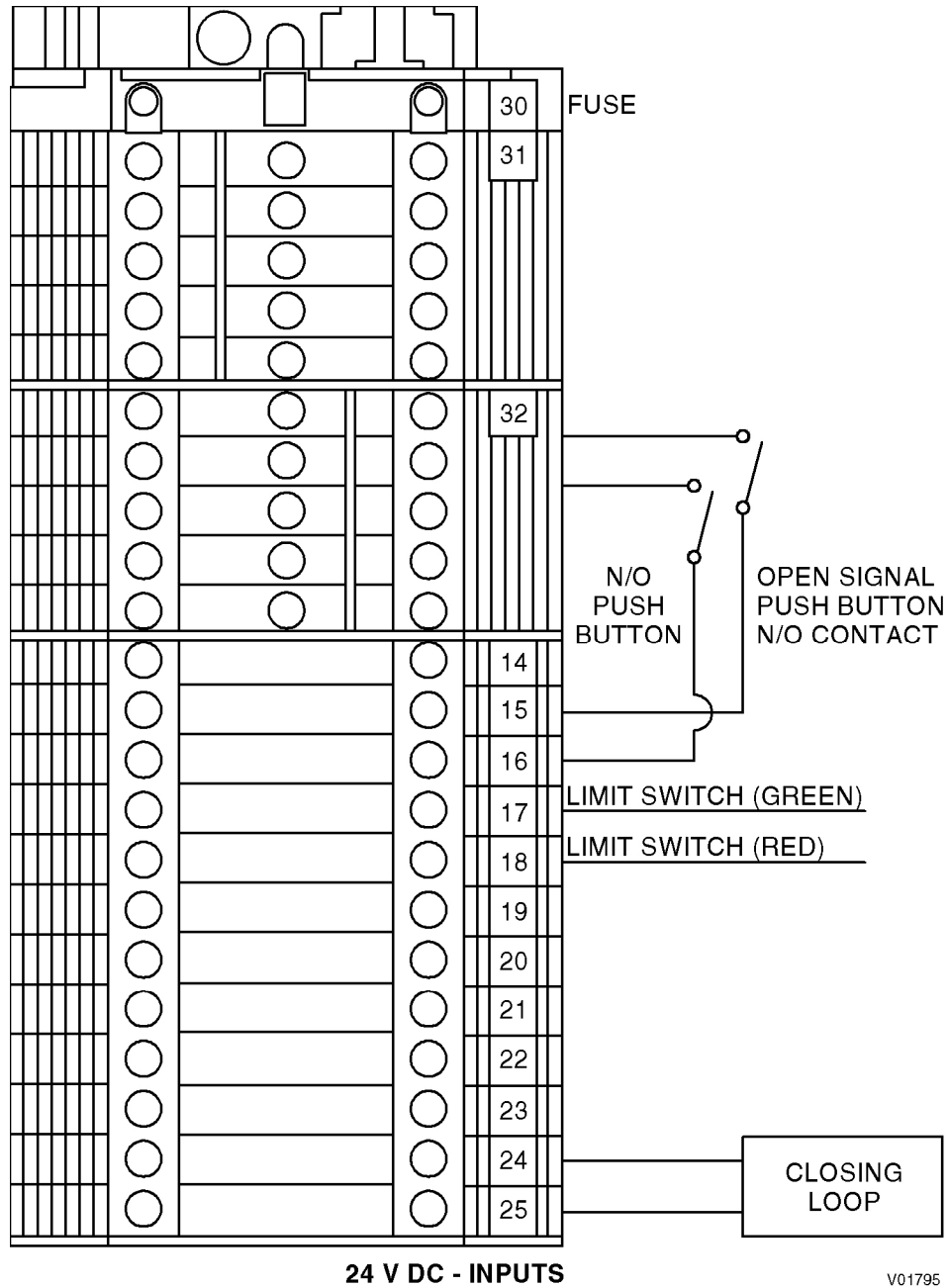

Figure 3-13. 24 V DC Wiring Diagram

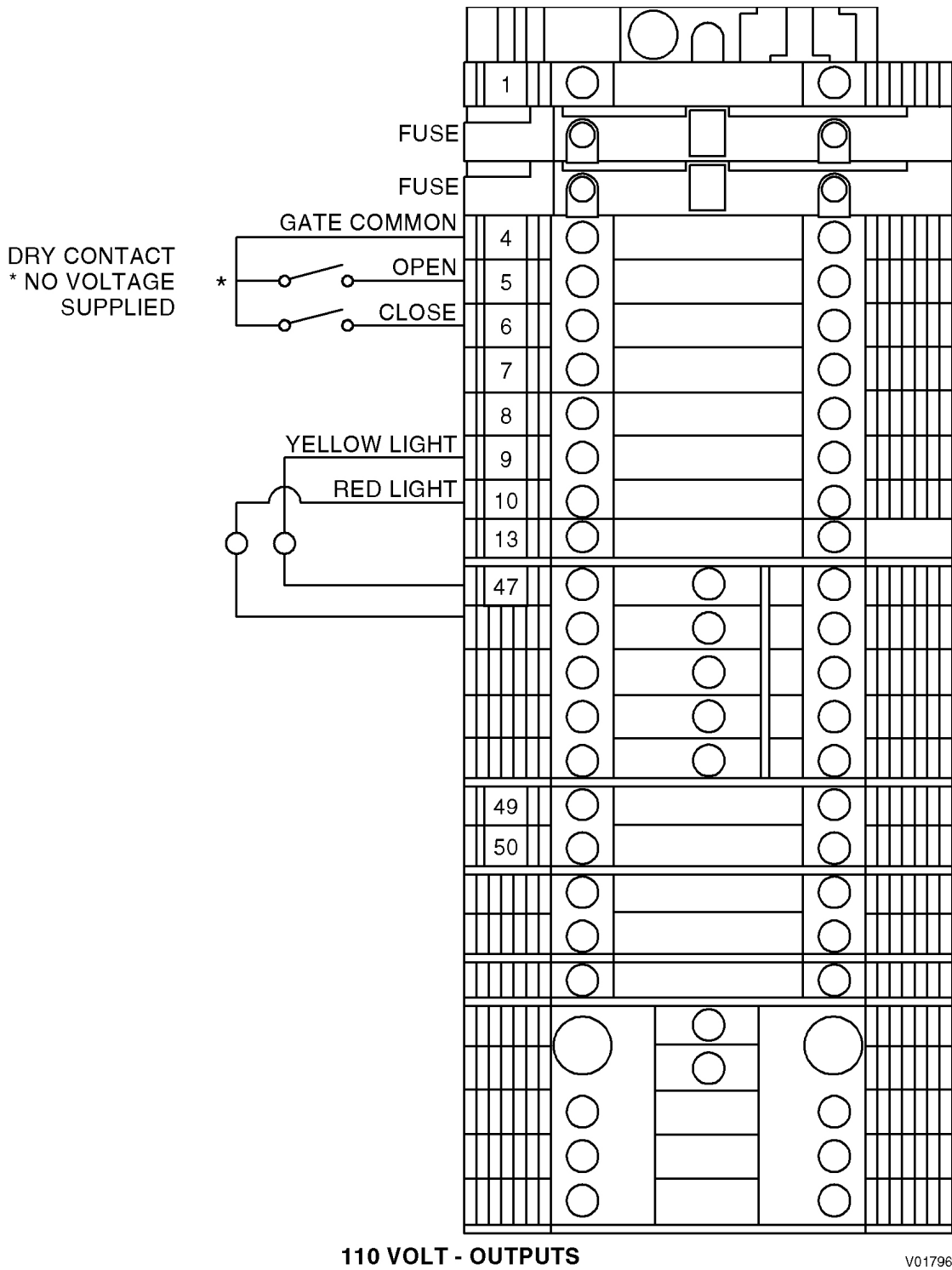

Figure 3-14. 110 V AC Wiring Diagram

Blank Page

SECTION 4. HYDRAULIC CONTROL UNIT WIRING

Table 4-1. Gate Access Controller I/O

Terminal No.	PLC Address	Description	Voltage	Notes
L1	X	Main Power Terminal Block	110 VAC	
1	X	Switched Power Terminal Block	110 VAC	
2	X	PLC Fuse Block	110 VAC	Fuse size 1A
3	X	PLC Output Fuse Block	110 VAC	Fuse size 8A
47	X	Neutral	110 VAC	
49	X	Pump Neutral	110 VAC	Pump Terminal
50	X	Pump Power	110 VAC	

Table 4-2. Gate Access Controller Input 24 VDC

Terminal No.	PLC Address	Description	Voltage	Notes
30	X	Fuse block F4 +24 VDC fusing PLC power supply	+24 VDC	Fuse size 500mA
31	X	-24 VDC PLC sensor power return	-24 VDC	
32	X	Fused from F4 +24 VDC fusing PLC sensor power supply	+24 VDC	Fused @ 500 mA
15	I0.0	Trip signal	Sinking 24 VDC	
16	I0.1	Retract signal		
17	I0.2	Position switch extended signal (Down position)	Sinking 24 VDC	
18	I0.3	Position switch retracted signal (Up position)	Sinking 24 VDC	
19	-	-	-	
20	-	-	-	
21	-	-	-	
22	-	-	-	
23	I0.4	Pump contactor auxiliary contact (Pump running)	Sinking 24 VDC	

Table 4-3. Gate Access Controller Output

Terminal No.	PLC Address	Description	Voltage	Notes
4	3L	Gate arm controller signal common	N/A	No power from controller
5	Q 0.7	Gate arm controller signal open dry contact	N/A	No power from controller
6	Q 1.0	Gate arm controller signal closed dry contact	N/A	No power from controller
7	Q 0.0	Solenoid Control Valve (down/open)	120 VAC	
8	Q 0.1	Solenoid Control Valve (up/close)	120 VAC	
9	Q 0.3	Green / Yellow light	120 VAC	
10	Q 0.4	Red light	120 VAC	
11	-	-	-	
12	-	-	-	
13	Q 0.2	Pump contactor	120 VAC	

Table 4-4. Terminal Board 1

From	To
30	PLC L (24 VDC+)
31	PLC M (24VDC -)
22	PLC 1.5
21	PLC 1.4
20	PLC 1.0
19	PLC 0.7
23	PLC 0.4
18	PLC 0.3
17	PLC 0.2
16	PLC 0.1
15	PLC 0.0
-	PLC 1M
32 jumper to 30	
23	SIRIUS 3R, 2-T1
14	Inductive Loop Detector 5
32	SIRIUS 3R, 1-L1

Table 4-5. Terminal Board 2

From	To
-	Siemens 1L loop 2L
-	7 0.0
Jumper 1 to 2	-
Jumper 3 to 4	-
1	SIRIUS 3R, 5L3
4	3L
5	Q 0.7
6	Q 1.0
7	Q 0.0
8	Q 0.1
9	Q 0.3
10	Q 0.4
13	Q 0.2
-	Q 0.2 to SIRIUS 3R, A1
N-PLC	Siemens N
N-CR-A2	SIRIUS 3R, A2
Terminal Ground	Siemens GRD
7 (GRN)	Solenoid Control Valve UP
8 (RED)	Solenoid Control Valve Down
47	Solenoid Control Valve UP
47	Solenoid Control Valve Down
49 (White)	Hydraulic Motor
50 (Black)	SIRIUS 3R, 6-T3
49	Jumpered from input power source
50	Jumpered from input power source

Table 4-6. Inductive Loop Vehicle Detector

1	TB2 (Grey/Black)
2	TB2 (WHT)
3	NC
4	TB2 (GRN)
5	TB1-14 (Orange)
6	NC
7	TB1-24 (Light Grey)
8	TB1-25 (Dark Grey)
9	TB1-32 (RED)
10	NC
11	NC

Table 4-7. SIRIUS 3R

(Relay)	
A1	Siemens PLC Q 0.2
A2	TB2-N-CR
1 L1	TB1-32
2 T1	TB1-23
5L3	TB2-1
6T3	TB2-50

Table 4-8. Manual Override Switch

Up	TB1-15
Center	TB1-32
Down	TB1-16

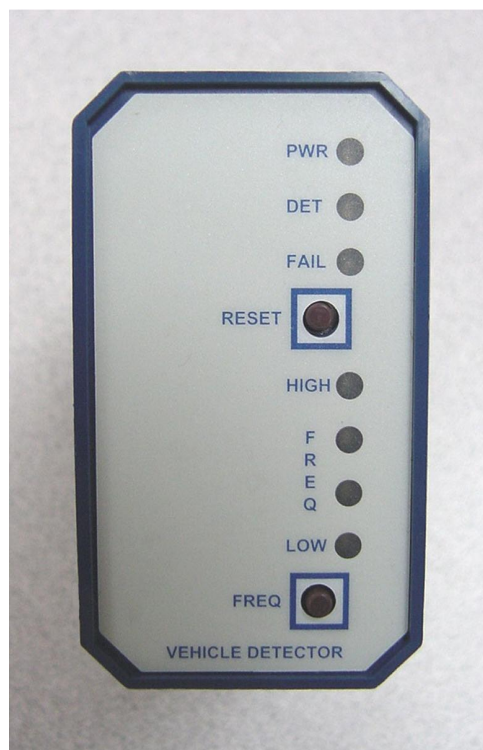

V01744

Figure 4-1. Loop Detector Panel Indicators

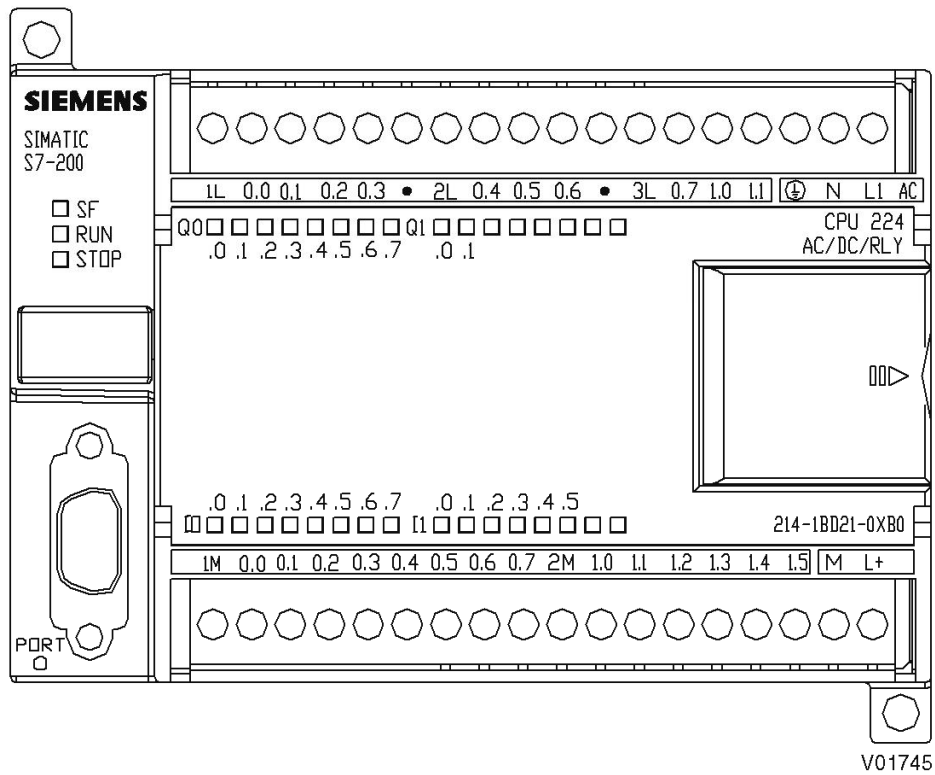
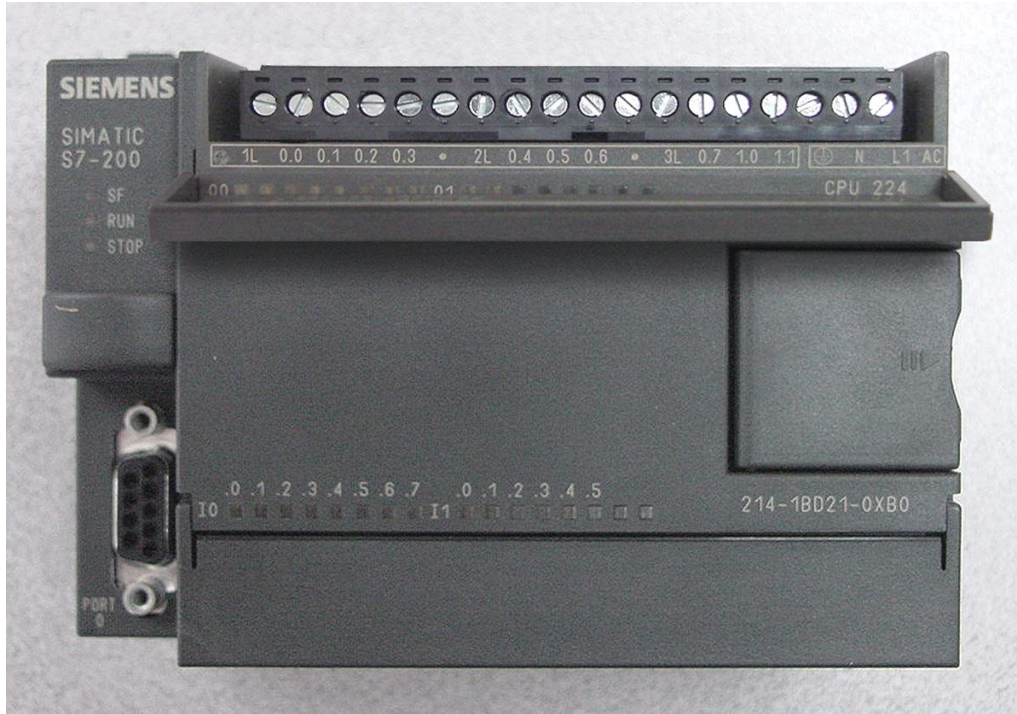

Figure 4-2. Programmable Logic Controller

Blank Page

SECTION 5. MAINTENANCE

Scheduled Maintenance

WARNING: BEFORE YOU USE A MATERIAL, REFER TO THE MANUFACTURERS' MATERIAL SAFETY DATA SHEETS FOR SAFETY INFORMATION. SOME MATERIALS CAN BE DANGEROUS.

Table 5-1. Scheduled Maintenance

Period	Maintenance
Daily	Check HPU manifold for leakage.
Weekly	Check HPU reservoir fluid level.
Semi-Annually	1. Change hydraulic fluid (heavy use). 2. Check spike shaft mount bushing for wear.
Annually	Change hydraulic fluid (moderate use).

Table 5-2. Material Part Numbers

Description	Brand	Part No.	Quantity
Hydraulic Fluid	DEXRON III ATF Fluid	HO-2 (cold climate)	1 gallon
		HO-2A (warm climate)	

Routine Maintenance

WARNING: STAY CLEAR OF THE SPIKE RETRACTION AREA. THE SPIKES ARE HYDRAULICALLY ACTIVATED AND CAN CAUSE PINCHING OR DISMEMBERMENT.

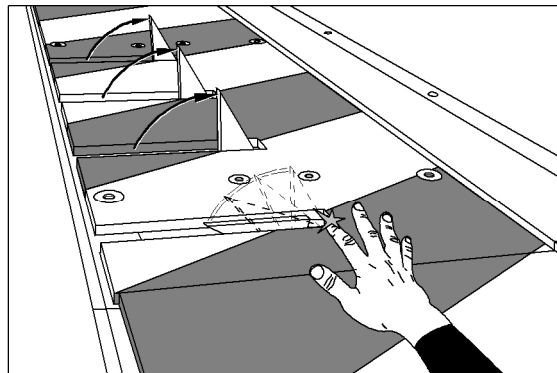
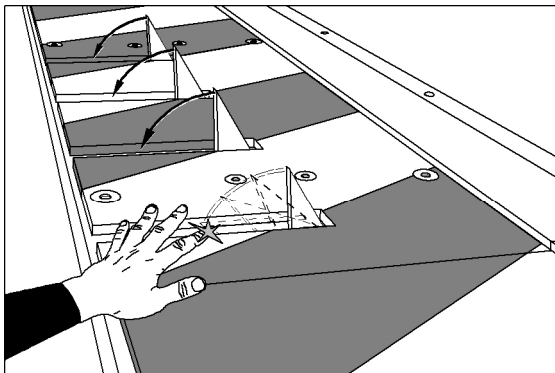

V01727

WARNING: THIS UNIT CONTAINS A THERMALLY FUSED ELECTRIC MOTOR. IF THE MOTOR STOPS DO NOT ASSUME POWER IS NOT PRESENT. UNEXPECTED MOTOR START-UP IS POSSIBLE AFTER PROTECTOR TRIPS. DISCONNECT POWER FROM CIRCUIT BEFORE PERFORMING ANY SERVICE TO THE MOTOR. WHEN POWER IS RECONNECTED, RESET PROTECTOR BEFORE ACTIVATING SYSTEM.

Spike Shaft Travel Adjustment

The spike shaft must be properly adjusted to prevent over travel of the shaft in the up or down position, and to allow the hydraulic pump to shut off when the proper travel limit is met. If the travel limit of the spike shaft is exceeded, the hydraulic motor will continue to run for approximately 5 seconds before shutting down.

Up Travel Adjustment

1. Apply power to the unit.
2. Actuate the up/down toggle switch on the control panel to position the spike shaft with the spikes extended (up).
3. Check the position of the spikes in relation to the slotted top plate. In the extended position, there should be approximately 1/4 inch between the back of the spike and the edge of the slotted top plate (Figure 5-1).

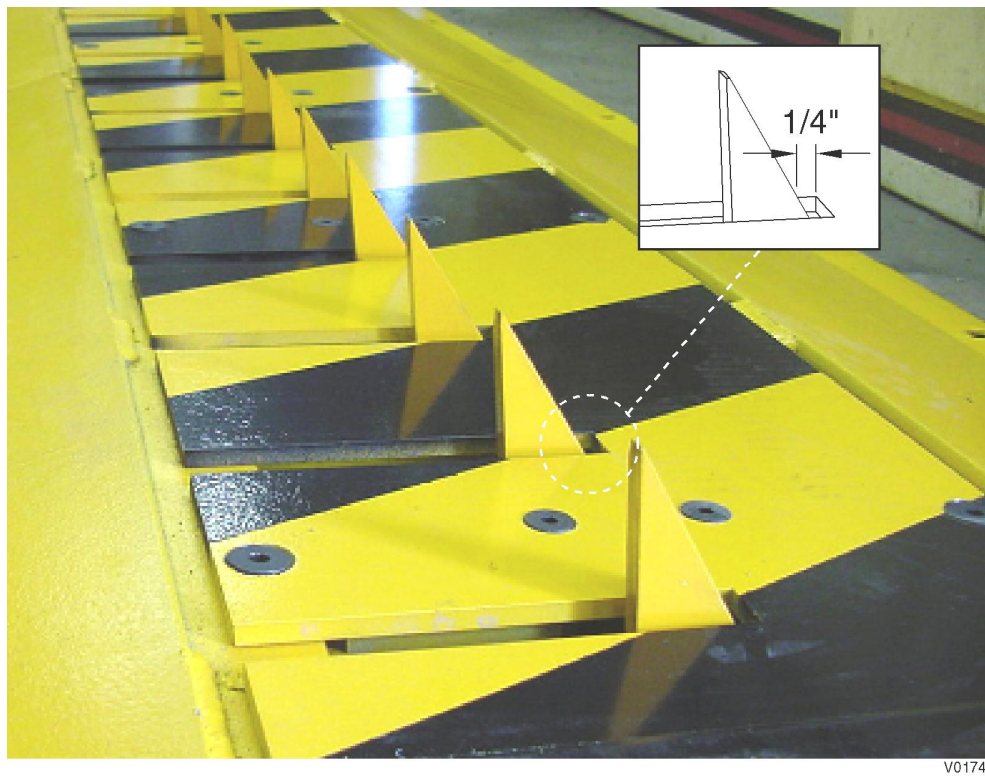

V01746

Figure 5-1. Spike Up Travel Stop

4. To adjust the up travel limit of the spikes, loosen the two setscrews on top of the up limit switch (Figure 5-2).
5. Move the up limit switch right or left and tighten the setscrews. Moving the up-limit switch to the right will cause the travel of the spikes to increase. Moving the up limit switch to the left will cause the travel of the spikes to decrease.
6. Actuate the up/down toggle switch down and then up to check for the proper travel of the spike shaft.
7. Repeat step 3 through step 6 until the spike shaft is positioned properly.

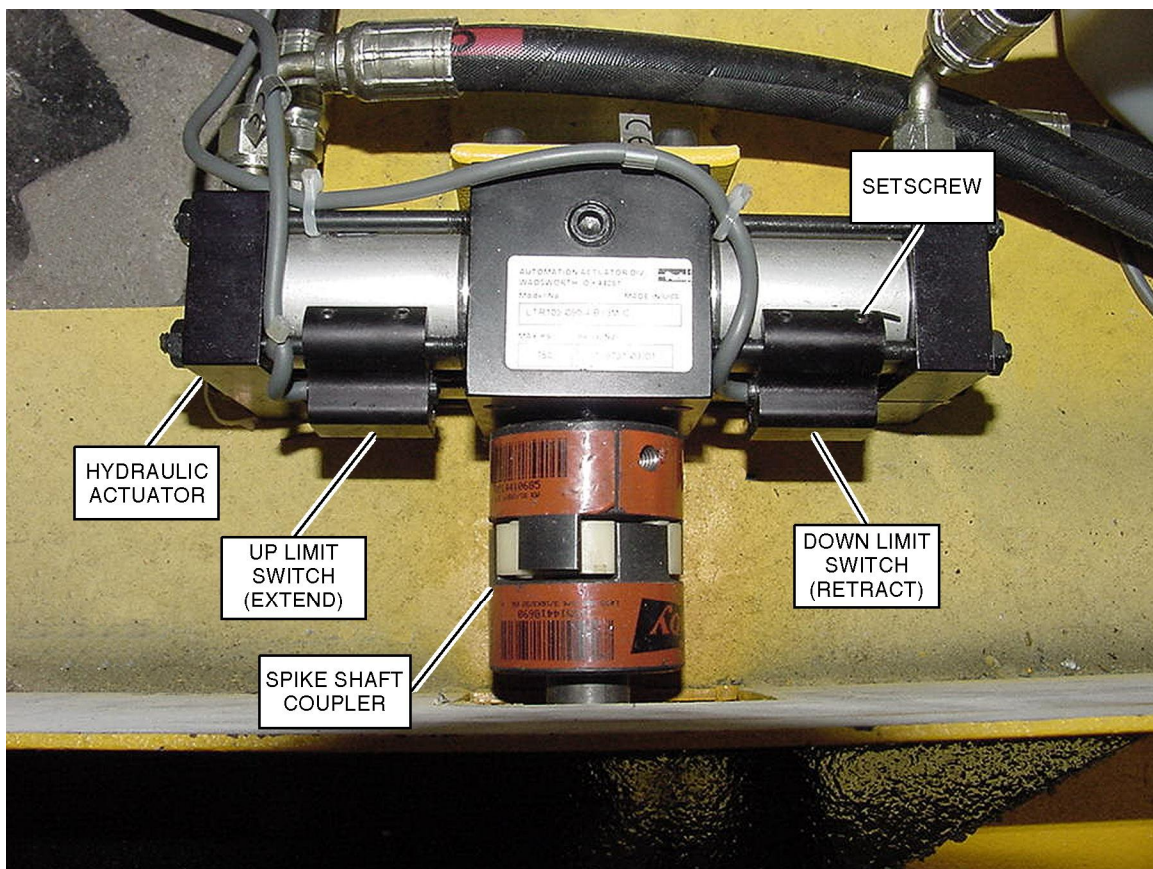

V01747

Figure 5-2. Limit Switch Adjustment

Down Travel Adjustment

1. Apply power to the unit.
2. Actuate the up/down toggle switch on the control panel to position the spike shaft with the spikes retracted (down).
3. Check the position of the spikes in relation to the slotted top plate. In the retracted position, the spikes should be 1/8 to 1/4 inch below the surface of the slotted top plate.
4. To adjust the down travel limit of the spikes, loosen the two setscrews on top of the down limit switch (Figure 5-2).
5. Move the down limit switch right or left and tighten the setscrews. Moving the down limit switch to the right will cause the travel of the spikes to increase. Moving the down limit switch to the left will cause the travel of the spikes to decrease.
6. Actuate the up/down toggle switch up and then down to check for the proper travel of the spike shaft.
7. Repeat step 3 through step 6 until the spike shaft is positioned properly.

Debris/Drainage

Make periodic inspections for debris that accumulates in the units. Debris can block the drainage channels and cause rusting of the equipment.

APPENDIX A

Use Powers Fasteners, Stainless Steel Power Stud™ wedge anchor, ½ x 2 ¾, PN21WW-0500275 or equivalent.

Installation Procedures

Using the proper diameter bit, drill a hole into the base material to a depth of at least 1/2" or one anchor diameter deeper than the embedment required. The tolerances of the drill bit used should meet the requirements of ANSI Standard B94.12.

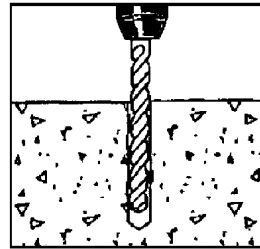

Blow the hole clean of dust and other material. Position the washer on the anchor and thread on the nut.

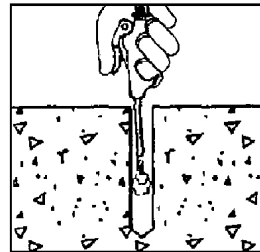

Threaded Version

Drive the anchor through the fixture into the anchor hole until the nut and washer are firmly seated against the fixture. Be sure the anchor is driven to the required embedment depth.

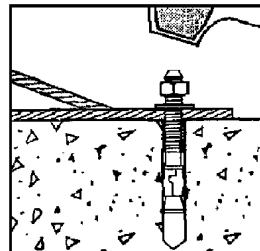

Tighten the anchor by turning the nut 3 to 4 turns or by applying the guide installation torque from the finger tight position.

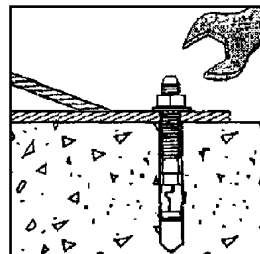

V01748

Blank Page

REV	REV	DATE	DESCRIPTION
1	1	12/15/00	ISSUED FOR CONSTRUCTION
2	2	01/10/01	REVISED TO ADD FIELD CONNECTIONS
3	3	02/10/01	REVISED TO ADD FIELD CONNECTIONS
4	4	03/10/01	REVISED TO ADD FIELD CONNECTIONS
5	5	04/10/01	REVISED TO ADD FIELD CONNECTIONS
6	6	05/10/01	REVISED TO ADD FIELD CONNECTIONS
7	7	06/10/01	REVISED TO ADD FIELD CONNECTIONS
8	8	07/10/01	REVISED TO ADD FIELD CONNECTIONS
9	9	08/10/01	REVISED TO ADD FIELD CONNECTIONS
10	10	09/10/01	REVISED TO ADD FIELD CONNECTIONS
11	11	10/10/01	REVISED TO ADD FIELD CONNECTIONS
12	12	11/10/01	REVISED TO ADD FIELD CONNECTIONS
13	13	12/10/01	REVISED TO ADD FIELD CONNECTIONS
14	14	01/10/02	REVISED TO ADD FIELD CONNECTIONS
15	15	02/10/02	REVISED TO ADD FIELD CONNECTIONS
16	16	03/10/02	REVISED TO ADD FIELD CONNECTIONS
17	17	04/10/02	REVISED TO ADD FIELD CONNECTIONS
18	18	05/10/02	REVISED TO ADD FIELD CONNECTIONS
19	19	06/10/02	REVISED TO ADD FIELD CONNECTIONS
20	20	07/10/02	REVISED TO ADD FIELD CONNECTIONS
21	21	08/10/02	REVISED TO ADD FIELD CONNECTIONS
22	22	09/10/02	REVISED TO ADD FIELD CONNECTIONS
23	23	10/10/02	REVISED TO ADD FIELD CONNECTIONS
24	24	11/10/02	REVISED TO ADD FIELD CONNECTIONS
25	25	12/10/02	REVISED TO ADD FIELD CONNECTIONS
26	26	01/10/03	REVISED TO ADD FIELD CONNECTIONS
27	27	02/10/03	REVISED TO ADD FIELD CONNECTIONS
28	28	03/10/03	REVISED TO ADD FIELD CONNECTIONS
29	29	04/10/03	REVISED TO ADD FIELD CONNECTIONS
30	30	05/10/03	REVISED TO ADD FIELD CONNECTIONS
31	31	06/10/03	REVISED TO ADD FIELD CONNECTIONS
32	32	07/10/03	REVISED TO ADD FIELD CONNECTIONS
33	33	08/10/03	REVISED TO ADD FIELD CONNECTIONS
34	34	09/10/03	REVISED TO ADD FIELD CONNECTIONS
35	35	10/10/03	REVISED TO ADD FIELD CONNECTIONS
36	36	11/10/03	REVISED TO ADD FIELD CONNECTIONS
37	37	12/10/03	REVISED TO ADD FIELD CONNECTIONS
38	38	01/10/04	REVISED TO ADD FIELD CONNECTIONS
39	39	02/10/04	REVISED TO ADD FIELD CONNECTIONS
40	40	03/10/04	REVISED TO ADD FIELD CONNECTIONS
41	41	04/10/04	REVISED TO ADD FIELD CONNECTIONS
42	42	05/10/04	REVISED TO ADD FIELD CONNECTIONS
43	43	06/10/04	REVISED TO ADD FIELD CONNECTIONS
44	44	07/10/04	REVISED TO ADD FIELD CONNECTIONS
45	45	08/10/04	REVISED TO ADD FIELD CONNECTIONS
46	46	09/10/04	REVISED TO ADD FIELD CONNECTIONS
47	47	10/10/04	REVISED TO ADD FIELD CONNECTIONS
48	48	11/10/04	REVISED TO ADD FIELD CONNECTIONS
49	49	12/10/04	REVISED TO ADD FIELD CONNECTIONS
50	50	01/10/05	REVISED TO ADD FIELD CONNECTIONS
51	51	02/10/05	REVISED TO ADD FIELD CONNECTIONS
52	52	03/10/05	REVISED TO ADD FIELD CONNECTIONS
53	53	04/10/05	REVISED TO ADD FIELD CONNECTIONS
54	54	05/10/05	REVISED TO ADD FIELD CONNECTIONS
55	55	06/10/05	REVISED TO ADD FIELD CONNECTIONS
56	56	07/10/05	REVISED TO ADD FIELD CONNECTIONS
57	57	08/10/05	REVISED TO ADD FIELD CONNECTIONS
58	58	09/10/05	REVISED TO ADD FIELD CONNECTIONS
59	59	10/10/05	REVISED TO ADD FIELD CONNECTIONS
60	60	11/10/05	REVISED TO ADD FIELD CONNECTIONS
61	61	12/10/05	REVISED TO ADD FIELD CONNECTIONS
62	62	01/10/06	REVISED TO ADD FIELD CONNECTIONS
63	63	02/10/06	REVISED TO ADD FIELD CONNECTIONS
64	64	03/10/06	REVISED TO ADD FIELD CONNECTIONS
65	65	04/10/06	REVISED TO ADD FIELD CONNECTIONS
66	66	05/10/06	REVISED TO ADD FIELD CONNECTIONS
67	67	06/10/06	REVISED TO ADD FIELD CONNECTIONS
68	68	07/10/06	REVISED TO ADD FIELD CONNECTIONS
69	69	08/10/06	REVISED TO ADD FIELD CONNECTIONS
70	70	09/10/06	REVISED TO ADD FIELD CONNECTIONS
71	71	10/10/06	REVISED TO ADD FIELD CONNECTIONS
72	72	11/10/06	REVISED TO ADD FIELD CONNECTIONS
73	73	12/10/06	REVISED TO ADD FIELD CONNECTIONS
74	74	01/10/07	REVISED TO ADD FIELD CONNECTIONS
75	75	02/10/07	REVISED TO ADD FIELD CONNECTIONS
76	76	03/10/07	REVISED TO ADD FIELD CONNECTIONS
77	77	04/10/07	REVISED TO ADD FIELD CONNECTIONS
78	78	05/10/07	REVISED TO ADD FIELD CONNECTIONS
79	79	06/10/07	REVISED TO ADD FIELD CONNECTIONS
80	80	07/10/07	REVISED TO ADD FIELD CONNECTIONS
81	81	08/10/07	REVISED TO ADD FIELD CONNECTIONS
82	82	09/10/07	REVISED TO ADD FIELD CONNECTIONS
83	83	10/10/07	REVISED TO ADD FIELD CONNECTIONS
84	84	11/10/07	REVISED TO ADD FIELD CONNECTIONS
85	85	12/10/07	REVISED TO ADD FIELD CONNECTIONS
86	86	01/10/08	REVISED TO ADD FIELD CONNECTIONS
87	87	02/10/08	REVISED TO ADD FIELD CONNECTIONS
88	88	03/10/08	REVISED TO ADD FIELD CONNECTIONS
89	89	04/10/08	REVISED TO ADD FIELD CONNECTIONS
90	90	05/10/08	REVISED TO ADD FIELD CONNECTIONS
91	91	06/10/08	REVISED TO ADD FIELD CONNECTIONS
92	92	07/10/08	REVISED TO ADD FIELD CONNECTIONS
93	93	08/10/08	REVISED TO ADD FIELD CONNECTIONS
94	94	09/10/08	REVISED TO ADD FIELD CONNECTIONS
95	95	10/10/08	REVISED TO ADD FIELD CONNECTIONS
96	96	11/10/08	REVISED TO ADD FIELD CONNECTIONS
97	97	12/10/08	REVISED TO ADD FIELD CONNECTIONS
98	98	01/10/09	REVISED TO ADD FIELD CONNECTIONS
99	99	02/10/09	REVISED TO ADD FIELD CONNECTIONS
100	100	03/10/09	REVISED TO ADD FIELD CONNECTIONS

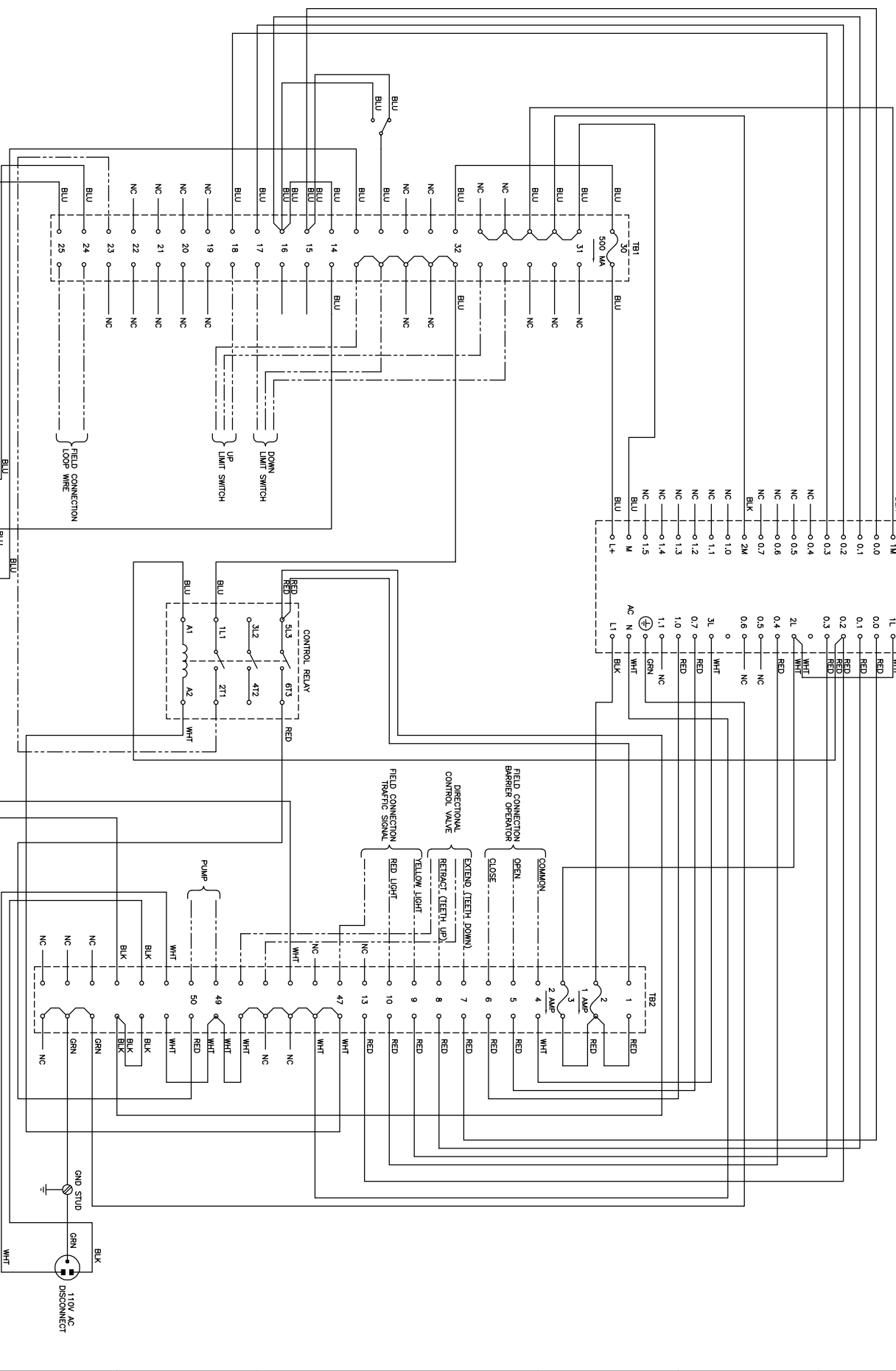

REV	DESCRIPTION	DATE	BY
1	ISSUED FOR CONSTRUCTION	12/15/00	SPK
2	REVISED TO ADD FIELD CONNECTIONS	01/10/01	SPK
3	REVISED TO ADD FIELD CONNECTIONS	02/10/01	SPK
4	REVISED TO ADD FIELD CONNECTIONS	03/10/01	SPK
5	REVISED TO ADD FIELD CONNECTIONS	04/10/01	SPK
6	REVISED TO ADD FIELD CONNECTIONS	05/10/01	SPK
7	REVISED TO ADD FIELD CONNECTIONS	06/10/01	SPK
8	REVISED TO ADD FIELD CONNECTIONS	07/10/01	SPK
9	REVISED TO ADD FIELD CONNECTIONS	08/10/01	SPK
10	REVISED TO ADD FIELD CONNECTIONS	09/10/01	SPK
11	REVISED TO ADD FIELD CONNECTIONS	10/10/01	SPK
12	REVISED TO ADD FIELD CONNECTIONS	11/10/01	SPK
13	REVISED TO ADD FIELD CONNECTIONS	12/10/01	SPK
14	REVISED TO ADD FIELD CONNECTIONS	01/10/02	SPK
15	REVISED TO ADD FIELD CONNECTIONS	02/10/02	SPK
16	REVISED TO ADD FIELD CONNECTIONS	03/10/02	SPK
17	REVISED TO ADD FIELD CONNECTIONS	04/10/02	SPK
18	REVISED TO ADD FIELD CONNECTIONS	05/10/02	SPK
19	REVISED TO ADD FIELD CONNECTIONS	06/10/02	SPK
20	REVISED TO ADD FIELD CONNECTIONS	07/10/02	SPK
21	REVISED TO ADD FIELD CONNECTIONS	08/10/02	SPK
22	REVISED TO ADD FIELD CONNECTIONS	09/10/02	SPK
23	REVISED TO ADD FIELD CONNECTIONS	10/10/02	SPK
24	REVISED TO ADD FIELD CONNECTIONS	11/10/02	SPK
25	REVISED TO ADD FIELD CONNECTIONS	12/10/02	SPK
26	REVISED TO ADD FIELD CONNECTIONS	01/10/03	SPK
27	REVISED TO ADD FIELD CONNECTIONS	02/10/03	SPK
28	REVISED TO ADD FIELD CONNECTIONS	03/10/03	SPK
29	REVISED TO ADD FIELD CONNECTIONS	04/10/03	SPK
30	REVISED TO ADD FIELD CONNECTIONS	05/10/03	SPK
31	REVISED TO ADD FIELD CONNECTIONS	06/10/03	SPK
32	REVISED TO ADD FIELD CONNECTIONS	07/10/03	SPK
33	REVISED TO ADD FIELD CONNECTIONS	08/10/03	SPK
34	REVISED TO ADD FIELD CONNECTIONS	09/10/03	SPK
35	REVISED TO ADD FIELD CONNECTIONS	10/10/03	SPK
36	REVISED TO ADD FIELD CONNECTIONS	11/10/03	SPK
37	REVISED TO ADD FIELD CONNECTIONS	12/10/03	SPK
38	REVISED TO ADD FIELD CONNECTIONS	01/10/04	SPK
39	REVISED TO ADD FIELD CONNECTIONS	02/10/04	SPK
40	REVISED TO ADD FIELD CONNECTIONS	03/10/04	SPK
41	REVISED TO ADD FIELD CONNECTIONS	04/10/04	SPK
42	REVISED TO ADD FIELD CONNECTIONS	05/10/04	SPK
43	REVISED TO ADD FIELD CONNECTIONS	06/10/04	SPK
44	REVISED TO ADD FIELD CONNECTIONS	07/10/04	SPK
45	REVISED TO ADD FIELD CONNECTIONS	08/10/04	SPK
46	REVISED TO ADD FIELD CONNECTIONS	09/10/04	SPK
47	REVISED TO ADD FIELD CONNECTIONS	10/10/04	SPK
48	REVISED TO ADD FIELD CONNECTIONS	11/10/04	SPK
49	REVISED TO ADD FIELD CONNECTIONS	12/10/04	SPK
50	REVISED TO ADD FIELD CONNECTIONS	01/10/05	SPK
51	REVISED TO ADD FIELD CONNECTIONS	02/10/05	SPK
52	REVISED TO ADD FIELD CONNECTIONS	03/10/05	SPK
53	REVISED TO ADD FIELD CONNECTIONS	04/10/05	SPK
54	REVISED TO ADD FIELD CONNECTIONS	05/10/05	SPK
55	REVISED TO ADD FIELD CONNECTIONS	06/10/05	SPK
56	REVISED TO ADD FIELD CONNECTIONS	07/10/05	SPK
57	REVISED TO ADD FIELD CONNECTIONS	08/10/05	SPK
58	REVISED TO ADD FIELD CONNECTIONS	09/10/05	SPK
59	REVISED TO ADD FIELD CONNECTIONS	10/10/05	SPK
60	REVISED TO ADD FIELD CONNECTIONS	11/10/05	SPK
61	REVISED TO ADD FIELD CONNECTIONS	12/10/05	SPK
62	REVISED TO ADD FIELD CONNECTIONS	01/10/06	SPK
63	REVISED TO ADD FIELD CONNECTIONS	02/10/06	SPK
64	REVISED TO ADD FIELD CONNECTIONS	03/10/06	SPK
65	REVISED TO ADD FIELD CONNECTIONS	04/10/06	SPK
66	REVISED TO ADD FIELD CONNECTIONS	05/10/06	SPK
67	REVISED TO ADD FIELD CONNECTIONS	06/10/06	SPK
68	REVISED TO ADD FIELD CONNECTIONS	07/10/06	SPK
69	REVISED TO ADD FIELD CONNECTIONS	08/10/06	SPK
70	REVISED TO ADD FIELD CONNECTIONS	09/10/06	SPK
71	REVISED TO ADD FIELD CONNECTIONS	10/10/06	SPK
72	REVISED TO ADD FIELD CONNECTIONS	11/10/06	SPK
73	REVISED TO ADD FIELD CONNECTIONS	12/10/06	SPK
74	REVISED TO ADD FIELD CONNECTIONS	01/10/07	SPK
75	REVISED TO ADD FIELD CONNECTIONS	02/10/07	SPK
76	REVISED TO ADD FIELD CONNECTIONS	03/10/07	SPK
77	REVISED TO ADD FIELD CONNECTIONS	04/10/07	SPK
78	REVISED TO ADD FIELD CONNECTIONS	05/10/07	SPK
79	REVISED TO ADD FIELD CONNECTIONS	06/10/07	SPK
80	REVISED TO ADD FIELD CONNECTIONS	07/10/07	SPK
81	REVISED TO ADD FIELD CONNECTIONS	08/10/07	SPK
82	REVISED TO ADD FIELD CONNECTIONS	09/10/07	SPK
83	REVISED TO ADD FIELD CONNECTIONS	10/10/07	SPK
84	REVISED TO ADD FIELD CONNECTIONS	11/10/07	SPK
85	REVISED TO ADD FIELD CONNECTIONS	12/10/07	SPK
86	REVISED TO ADD FIELD CONNECTIONS	01/10/08	SPK
87	REVISED TO ADD FIELD CONNECTIONS	02/10/08	SPK
88	REVISED TO ADD FIELD CONNECTIONS	03/10/08	SPK
89	REVISED TO ADD FIELD CONNECTIONS	04/10/08	SPK
90	REVISED TO ADD FIELD CONNECTIONS	05/10/08	SPK
91	REVISED TO ADD FIELD CONNECTIONS	06/10/08	SPK
92	REVISED TO ADD FIELD CONNECTIONS	07/10/08	SPK
93	REVISED TO ADD FIELD CONNECTIONS	08/10/08	SPK
94	REVISED TO ADD FIELD CONNECTIONS	09/10/08	SPK
95	REVISED TO ADD FIELD CONNECTIONS	10/10/08	SPK
96	REVISED TO ADD FIELD CONNECTIONS	11/10/08	SPK
97	REVISED TO ADD FIELD CONNECTIONS	12/10/08	SPK
98	REVISED TO ADD FIELD CONNECTIONS	01/10/09	SPK
99	REVISED TO ADD FIELD CONNECTIONS	02/10/09	SPK
100	REVISED TO ADD FIELD CONNECTIONS	03/10/09	SPK

UNLESS OTHERWISE SPECIFIED, THE FOLLOWING INFORMATION SHALL APPLY TO ALL WORKMANSHIP AND MATERIALS TO BE INSTALLED UNDER THIS CONTRACT.

1. ALL WORKMANSHIP SHALL BE IN ACCORDANCE WITH THE LATEST EDITIONS OF THE NATIONAL ELECTRICAL CODE (NEC) AND THE NATIONAL FIRE ALARM AND SIGNAL CODE (NFPA 72).

2. ALL MATERIALS SHALL BE NEW AND OF THE HIGHEST QUALITY AVAILABLE.

3. THE CONTRACTOR SHALL BE RESPONSIBLE FOR OBTAINING ALL NECESSARY PERMITS AND INSURANCE.

4. THE CONTRACTOR SHALL MAINTAIN ACCESS TO ALL UTILITIES AND STRUCTURES AT ALL TIMES.

5. THE CONTRACTOR SHALL BE RESPONSIBLE FOR PROTECTING ALL EXISTING UTILITIES AND STRUCTURES.

6. THE CONTRACTOR SHALL BE RESPONSIBLE FOR THE PROTECTION OF ALL ADJACENT PROPERTIES AND UTILITIES.

7. THE CONTRACTOR SHALL BE RESPONSIBLE FOR THE PROTECTION OF ALL EXISTING UTILITIES AND STRUCTURES.

8. THE CONTRACTOR SHALL BE RESPONSIBLE FOR THE PROTECTION OF ALL ADJACENT PROPERTIES AND UTILITIES.

9. THE CONTRACTOR SHALL BE RESPONSIBLE FOR THE PROTECTION OF ALL EXISTING UTILITIES AND STRUCTURES.

10. THE CONTRACTOR SHALL BE RESPONSIBLE FOR THE PROTECTION OF ALL ADJACENT PROPERTIES AND UTILITIES.

REV	DESCRIPTION	DATE	BY
1	ISSUED FOR CONSTRUCTION	12/15/00	SPK
2	REVISED TO ADD FIELD CONNECTIONS	01/10/01	SPK
3	REVISED TO ADD FIELD CONNECTIONS	02/10/01	SPK
4	REVISED TO ADD FIELD CONNECTIONS	03/10/01	SPK
5	REVISED TO ADD FIELD CONNECTIONS	04/10/01	SPK
6	REVISED TO ADD FIELD CONNECTIONS	05/10/01	SPK
7	REVISED TO ADD FIELD CONNECTIONS	06/10/01	SPK
8	REVISED TO ADD FIELD CONNECTIONS	07/10/01	SPK
9	REVISED TO ADD FIELD CONNECTIONS	08/10/01	SPK
10	REVISED TO ADD FIELD CONNECTIONS	09/10/01	SPK
11	REVISED TO ADD FIELD CONNECTIONS	10/10/01	SPK
12	REVISED TO ADD FIELD CONNECTIONS	11/10/01	SPK
13	REVISED TO ADD FIELD CONNECTIONS	12/10/01	SPK
14	REVISED TO ADD FIELD CONNECTIONS	01/10/02	SPK
15	REVISED TO ADD FIELD CONNECTIONS	02/10/02	SPK
16	REVISED TO ADD FIELD CONNECTIONS	03/10/02	SPK
17	REVISED TO ADD FIELD CONNECTIONS	04/10/02	SPK
18	REVISED TO ADD FIELD CONNECTIONS	05/10/02	SPK
19	REVISED TO ADD FIELD CONNECTIONS	06/10/02	SPK
20	REVISED TO ADD FIELD CONNECTIONS	07/10/02	SPK
21	REVISED TO ADD FIELD CONNECTIONS	08/10/02	SPK
22	REVISED TO ADD FIELD CONNECTIONS	09/10/02	SPK
23	REVISED TO ADD FIELD CONNECTIONS	10/10/02	SPK
24	REVISED TO ADD FIELD CONNECTIONS	11/10/02	SPK
25	REVISED TO ADD FIELD CONNECTIONS	12/10/02	SPK
26	REVISED TO ADD FIELD CONNECTIONS	01/10/03	SPK
27	REVISED TO ADD FIELD CONNECTIONS	02/10/03	SPK
28	REVISED TO ADD FIELD CONNECTIONS	03/10/03	SPK
29	REVISED TO ADD FIELD CONNECTIONS	04/10/03	SPK
30	REVISED TO ADD FIELD CONNECTIONS	05/10/03	SPK
31	REVISED TO ADD FIELD CONNECTIONS	06/10/03	SPK
32	REVISED TO ADD FIELD CONNECTIONS	07/10/03	SPK